

Problem 3.4-9 A tapered bar AB of solid circular cross section is twisted by torques $T = 36,000$ lb-in. (see figure). The diameter of the bar varies linearly from d_A at the left-hand end to d_B at the right-hand end. The bar has length $L = 4.0$ ft and is made of an aluminum alloy having shear modulus of elasticity $G = 3.9 \times 10^6$ psi. The allowable shear stress in the bar is 15,000 psi and the allowable angle of twist is 3.0° .

If the diameter at end B is 1.5 times the diameter at end A , what is the minimum required diameter d_A at end A ? (*Hint:* Use the results of Example 3-5).

Solution 3.4-9 Tapered bar

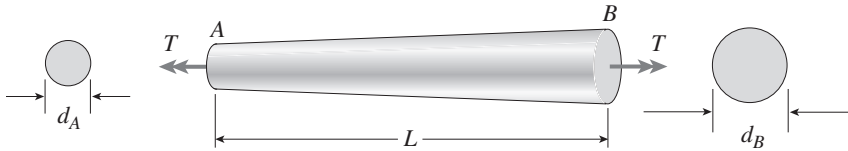

$$d_B = 1.5 d_A$$

$$T = 36,000 \text{ lb-in.}$$

$$L = 4.0 \text{ ft} = 48 \text{ in.}$$

$$G = 3.9 \times 10^6 \text{ psi}$$

$$\tau_{\text{allow}} = 15,000 \text{ psi}$$

$$\phi_{\text{allow}} = 3.0^\circ$$

$$= 0.0523599 \text{ rad}$$

MINIMUM DIAMETER BASED UPON ALLOWABLE SHEAR STRESS

$$\begin{aligned} \tau_{\text{max}} &= \frac{16T}{\pi d_A^3} & d_A^3 &= \frac{16T}{\pi \tau_{\text{allow}}} = \frac{16(36,000 \text{ lb-in.})}{\pi(15,000 \text{ psi})} \\ & & &= 12.2231 \text{ in.}^3 \\ d_A &= 2.30 \text{ in.} \end{aligned}$$

MINIMUM DIAMETER BASED UPON ALLOWABLE ANGLE OF TWIST (From Eq. 3-27)

$$\beta = d_B/d_A = 1.5$$

$$\phi = \frac{TL}{G(I_P)_A} \left(\frac{\beta^2 + \beta + 1}{3\beta^3} \right) = \frac{TL}{G(I_P)_A} (0.469136)$$

$$= \frac{(36,000 \text{ lb-in.})(48 \text{ in.})}{(3.9 \times 10^6 \text{ psi}) \left(\frac{\pi}{32} \right) d_A^4} (0.469136)$$

$$= \frac{2.11728 \text{ in.}^4}{d_A^4}$$

$$\begin{aligned} d_A^4 &= \frac{2.11728 \text{ in.}^4}{\phi_{\text{allow}}} = \frac{2.11728 \text{ in.}^4}{0.0523599 \text{ rad}} \\ &= 40.4370 \text{ in.}^4 \end{aligned}$$

$$d_A = 2.52 \text{ in.}$$

ANGLE OF TWIST GOVERNS

$$\text{Min. } d_A = 2.52 \text{ in.} \quad \leftarrow$$

Problem 3.4-10 The bar shown in the figure is tapered linearly from end A to end B and has a solid circular cross section. The diameter at the smaller end of the bar is $d_A = 25$ mm and the length is $L = 300$ mm. The bar is made of steel with shear modulus of elasticity $G = 82$ GPa.

If the torque $T = 180$ N · m and the allowable angle of twist is 0.3° , what is the minimum allowable diameter d_B at the larger end of the bar? (Hint: Use the results of Example 3-5.)

Solution 3.4-10 Tapered bar

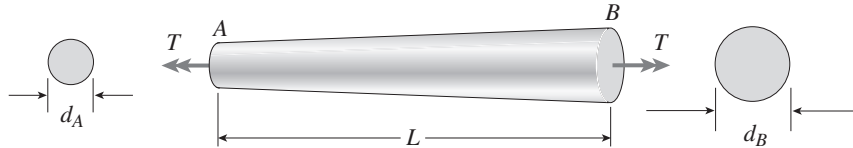

$$d_A = 25 \text{ mm}$$

$$L = 300 \text{ mm}$$

$$G = 82 \text{ GPa}$$

$$T = 180 \text{ N} \cdot \text{m}$$

$$\phi_{\text{allow}} = 0.3^\circ$$

Find d_B

DIAMETER BASED UPON ALLOWABLE ANGLE OF TWIST

(From Eq. 3-27)

$$\beta = \frac{d_B}{d_A}$$

$$\phi = \frac{TL}{G(I_p)_A} \left(\frac{\beta^2 + \beta + 1}{3\beta^3} \right) \quad (I_p)_A = \frac{\pi}{32} d_A^4$$

$$(0.3^\circ) \left(\frac{\pi \text{ rad}}{180 \text{ degrees}} \right) = \frac{(180 \text{ N} \cdot \text{m})(0.3 \text{ m})}{(82 \text{ GPa}) \left(\frac{\pi}{32} \right) (25 \text{ mm})^4} \left(\frac{\beta^2 + \beta + 1}{3\beta^3} \right)$$

$$0.304915 = \frac{\beta^2 + \beta + 1}{3\beta^3}$$

$$0.914745\beta^3 - \beta^2 - 1 = 0$$

SOLVE NUMERICALLY:

$$\beta = 1.94452$$

$$\text{Min. } d_B = \beta d_A = 48.6 \text{ mm} \quad \leftarrow$$

Problem 3.4-11 A uniformly tapered tube AB of hollow circular cross section is shown in the figure. The tube has constant wall thickness t and length L . The average diameters at the ends are d_A and $d_B = 2d_A$. The polar moment of inertia may be represented by the approximate formula $I_p \approx \pi d^3 t / 4$ (see Eq. 3-18).

Derive a formula for the angle of twist ϕ of the tube when it is subjected to torques T acting at the ends.

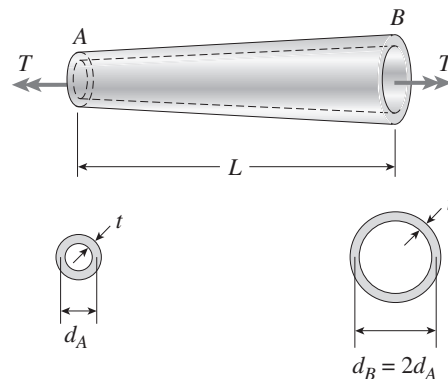

Solution 3.4-11 Tapered tube

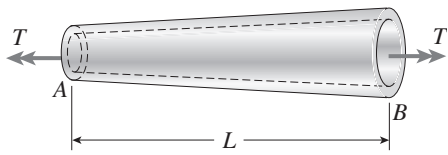

$t = \text{thickness (constant)}$
 $d_A, d_B = \text{average diameters at the ends}$
 $d_B = 2d_A \quad I_P = \frac{\pi d^3 t}{4} \text{ (approximate formula)}$

ANGLE OF TWIST

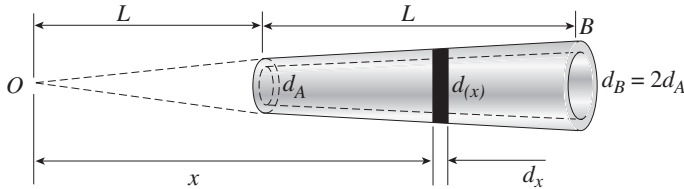

Take the origin of coordinates at point O.

$$d(x) = \frac{x}{2L} (d_B) = \frac{x}{L} d_A$$

$$I_P(x) = \frac{\pi [d(x)]^3 t}{4} = \frac{\pi t d_A^3}{4L^3} x^3$$

For element of length dx :

$$d\phi = \frac{T dx}{GI_P(x)} = \frac{T dx}{G \left(\frac{\pi t d_A^3}{4L^3} \right) x^3} = \frac{4TL^3}{\pi G t d_A^3} \cdot \frac{dx}{x^3}$$

For entire bar:

$$\phi = \int_L^{2L} d\phi = \frac{4TL^3}{\pi G t d_A^3} \int_L^{2L} \frac{dx}{x^3} = \frac{3TL}{2\pi G t d_A^3} \leftarrow$$

Problem 3.4-12 A prismatic bar AB of length L and solid circular cross section (diameter d) is loaded by a distributed torque of constant intensity t per unit distance (see figure).

- (a) Determine the maximum shear stress τ_{\max} in the bar.
- (b) Determine the angle of twist ϕ between the ends of the bar.

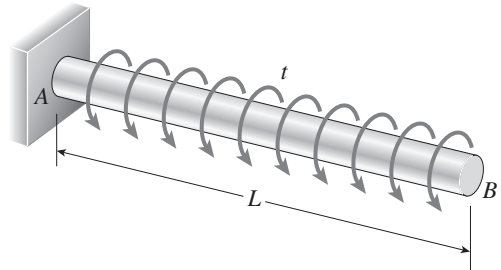

Solution 3.4-12 Bar with distributed torque

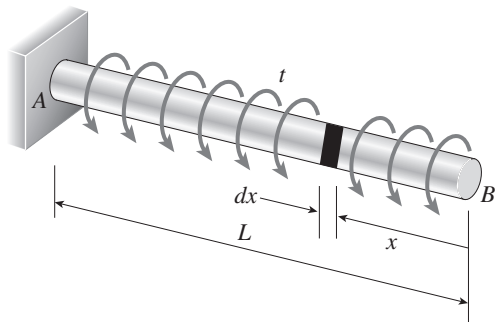

$t = \text{intensity of distributed torque}$

$d = \text{diameter}$

$G = \text{shear modulus of elasticity}$

(a) MAXIMUM SHEAR STRESS

$$T_{\max} = tL \quad \tau_{\max} = \frac{16T_{\max}}{\pi d^3} = \frac{16tL}{\pi d^3} \leftarrow$$

(b) ANGLE OF TWIST

$$T(x) = tx \quad I_P = \frac{\pi d^4}{32}$$

$$d\phi = \frac{T(x) dx}{GI_P} = \frac{32 tx dx}{\pi G d^4}$$

$$\phi = \int_0^L d\phi = \frac{32t}{\pi G d^4} \int_0^L x dx = \frac{16tL^2}{\pi G d^4} \leftarrow$$

Problem 3.4-13 A prismatic bar AB of solid circular cross section (diameter d) is loaded by a distributed torque (see figure). The intensity of the torque, that is, the torque per unit distance, is denoted $t(x)$ and varies linearly from a maximum value t_A at end A to zero at end B . Also, the length of the bar is L and the shear modulus of elasticity of the material is G .

- Determine the maximum shear stress τ_{\max} in the bar.
- Determine the angle of twist ϕ between the ends of the bar.

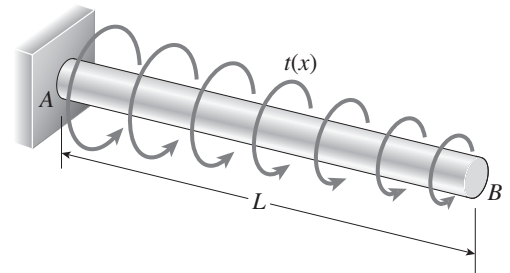

Solution 3.4-13 Bar with linearly varying torque

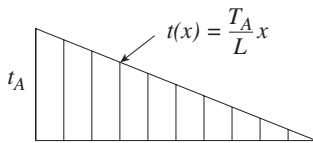
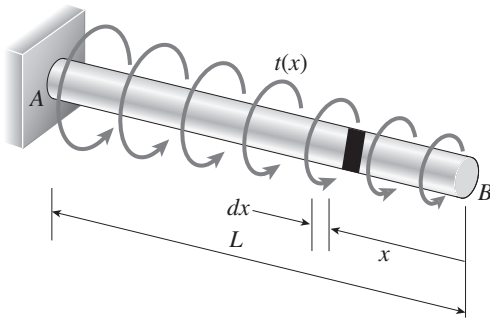

$t(x)$ = intensity of distributed torque

t_A = maximum intensity of torque

d = diameter

G = shear modulus

T_A = maximum torque

$$= \frac{1}{2} t_A L$$

(a) MAXIMUM SHEAR STRESS

$$\tau_{\max} = \frac{16T_{\max}}{\pi d^3} = \frac{16T_A}{\pi d^3} = \frac{8t_A L}{\pi d^3} \quad \leftarrow$$

(b) ANGLE OF TWIST

$T(x)$ = torque at distance x from end B

$$T(x) = \frac{t(x)x}{2} = \frac{t_A x^2}{2L} \quad I_P = \frac{\pi d^4}{32}$$

$$d\phi = \frac{T(x) dx}{GI_P} = \frac{16t_A x^2 dx}{\pi GLd^4}$$

$$\phi = \int_0^L d\phi = \frac{16t_A}{\pi GLd^4} \int_0^L x^2 dx = \frac{16t_A L^2}{3\pi Gd^4} \quad \leftarrow$$

Problem 3.4-14 A magnesium-alloy wire of diameter $d = 4$ mm and length L rotates inside a flexible tube in order to open or close a switch from a remote location (see figure). A torque T is applied manually (either clockwise or counterclockwise) at end B , thus twisting the wire inside the tube. At the other end A , the rotation of the wire operates a handle that opens or closes the switch.

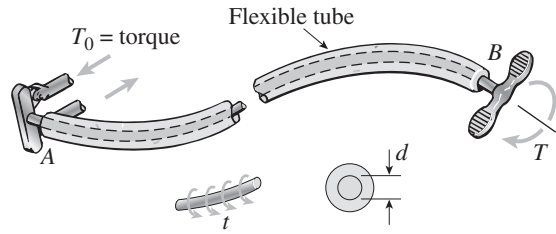

A torque $T_0 = 0.2 \text{ N} \cdot \text{m}$ is required to operate the switch. The torsional stiffness of the tube, combined with friction between the tube and the wire, induces a distributed torque of constant intensity $t = 0.04 \text{ N} \cdot \text{m/m}$ (torque per unit distance) acting along the entire length of the wire.

- (a) If the allowable shear stress in the wire is $\tau_{\text{allow}} = 30 \text{ MPa}$, what is the longest permissible length L_{max} of the wire?
- (b) If the wire has length $L = 4.0 \text{ m}$ and the shear modulus of elasticity for the wire is $G = 15 \text{ GPa}$, what is the angle of twist ϕ (in degrees) between the ends of the wire?

Solution 3.4-14 Wire inside a flexible tube

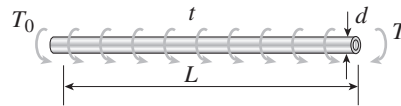

$d = 4 \text{ mm}$
 $T_0 = 0.2 \text{ N} \cdot \text{m}$
 $t = 0.04 \text{ N} \cdot \text{m/m}$

(a) MAXIMUM LENGTH L_{max}

$\tau_{\text{allow}} = 30 \text{ MPa}$
 Equilibrium: $T = tL + T_0$

From Eq. (3-12): $\tau_{\text{max}} = \frac{16T}{\pi d^3}$ $T = \frac{\pi d^3 \tau_{\text{max}}}{16}$

$$tL + T_0 = \frac{\pi d^3 \tau_{\text{max}}}{16}$$

$$L = \frac{1}{16t} (\pi d^3 \tau_{\text{max}} - 16T_0)$$

$$L_{\text{max}} = \frac{1}{16t} (\pi d^3 \tau_{\text{allow}} - 16T_0) \quad \leftarrow$$

Substitute numerical values: $L_{\text{max}} = 4.42 \text{ m} \quad \leftarrow$

(b) ANGLE OF TWIST ϕ
 $L = 4 \text{ m}$ $G = 15 \text{ GPa}$
 $\phi_1 =$ angle of twist due to distributed torque t

$$= \frac{16tL^2}{\pi G d^4} \text{ (from problem 3.4-12)}$$

$\phi_2 =$ angle of twist due to torque T_0
 $= \frac{T_0 L}{G I_P} = \frac{32 T_0 L}{\pi G d^4}$ (from Eq. 3-15)

$\phi =$ total angle of twist

$$= \phi_1 + \phi_2$$

$$\phi = \frac{16L}{\pi G d^4} (tL + 2T_0) \quad \leftarrow$$

Substitute numerical values:

$$\phi = 2.971 \text{ rad} = 170^\circ \quad \leftarrow$$

Pure Shear

Problem 3.5-1 A hollow aluminum shaft (see figure) has outside diameter $d_2 = 4.0$ in. and inside diameter $d_1 = 2.0$ in. When twisted by torques T , the shaft has an angle of twist per unit distance equal to $0.54^\circ/\text{ft}$. The shear modulus of elasticity of the aluminum is $G = 4.0 \times 10^6$ psi.

- Determine the maximum tensile stress σ_{\max} in the shaft.
- Determine the magnitude of the applied torques T .

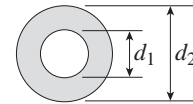
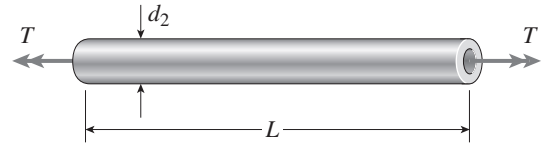

Problems 3.5-1, 3.5-2, and 3.5-3

Solution 3.5-1 Hollow aluminum shaft

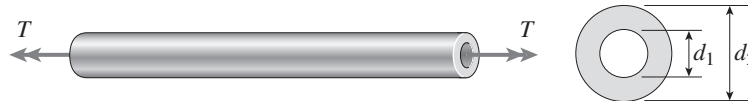

$$d_2 = 4.0 \text{ in.} \quad d_1 = 2.0 \text{ in.} \quad \theta = 0.54^\circ/\text{ft}$$

$$G = 4.0 \times 10^6 \text{ psi}$$

MAXIMUM SHEAR STRESS

$$\tau_{\max} = Gr\theta \text{ (from Eq. 3-7a)}$$

$$r = d_2/2 = 2.0 \text{ in.}$$

$$\theta = (0.54^\circ/\text{ft}) \left(\frac{1 \text{ ft}}{12 \text{ in.}} \right) \left(\frac{\pi \text{ rad}}{180 \text{ degree}} \right)$$

$$= 785.40 \times 10^{-6} \text{ rad/in.}$$

$$\tau_{\max} = (4.0 \times 10^6 \text{ psi})(2.0 \text{ in.})(785.40 \times 10^{-6} \text{ rad/in.})$$

$$= 6283.2 \text{ psi}$$

(a) MAXIMUM TENSILE STRESS

σ_{\max} occurs on a 45° plane and is equal to τ_{\max} .

$$\sigma_{\max} = \tau_{\max} = 6280 \text{ psi} \quad \leftarrow$$

(b) APPLIED TORQUE

Use the torsion formula $\tau_{\max} = \frac{Tr}{I_p}$

$$T = \frac{\tau_{\max} I_p}{r} \quad I_p = \frac{\pi}{32} [(4.0 \text{ in.})^4 - (2.0 \text{ in.})^4]$$

$$= 23.562 \text{ in.}^4$$

$$T = \frac{(6283.2 \text{ psi})(23.562 \text{ in.}^4)}{2.0 \text{ in.}}$$

$$= 74,000 \text{ lb-in.} \quad \leftarrow$$

Problem 3.5-2 A hollow steel bar ($G = 80 \text{ GPa}$) is twisted by torques T (see figure). The twisting of the bar produces a maximum shear strain $\gamma_{\max} = 640 \times 10^{-6} \text{ rad}$. The bar has outside and inside diameters of 150 mm and 120 mm, respectively.

- (a) Determine the maximum tensile strain in the bar.
- (b) Determine the maximum tensile stress in the bar.
- (c) What is the magnitude of the applied torques T ?

Solution 3.5-2 Hollow steel bar



$$G = 80 \text{ GPa} \quad \gamma_{\max} = 640 \times 10^{-6} \text{ rad}$$

$$d_2 = 150 \text{ mm} \quad d_1 = 120 \text{ mm}$$

$$I_p = \frac{\pi}{32}(d_2^4 - d_1^4)$$

$$= \frac{\pi}{32}[(150 \text{ mm})^4 - (120 \text{ mm})^4]$$

$$= 29.343 \times 10^6 \text{ mm}^4$$

(a) MAXIMUM TENSILE STRAIN

$$\epsilon_{\max} = \frac{\gamma_{\max}}{2} = 320 \times 10^{-6} \quad \leftarrow$$

(b) MAXIMUM TENSILE STRESS

$$\tau_{\max} = G\gamma_{\max} = (80 \text{ GPa})(640 \times 10^{-6})$$

$$= 51.2 \text{ MPa}$$

$$\sigma_{\max} = \tau_{\max} = 51.2 \text{ MPa} \quad \leftarrow$$

(c) APPLIED TORQUES

Torsion formula: $\tau_{\max} = \frac{Tr}{I_p} = \frac{Td_2}{2I_p}$

$$T = \frac{2I_p\tau_{\max}}{d_2} = \frac{2(29.343 \times 10^6 \text{ mm}^4)(51.2 \text{ MPa})}{150 \text{ mm}}$$

$$= 20,030 \text{ N} \cdot \text{m}$$

$$= 20.0 \text{ kN} \cdot \text{m} \quad \leftarrow$$

Problem 3.5-3 A tubular bar with outside diameter $d_2 = 4.0 \text{ in.}$ is twisted by torques $T = 70.0 \text{ k-in.}$ (see figure). Under the action of these torques, the maximum tensile stress in the bar is found to be 6400 psi.

- (a) Determine the inside diameter d_1 of the bar.
- (b) If the bar has length $L = 48.0 \text{ in.}$ and is made of aluminum with shear modulus $G = 4.0 \times 10^6 \text{ psi}$, what is the angle of twist ϕ (in degrees) between the ends of the bar?
- (c) Determine the maximum shear strain γ_{\max} (in radians)?

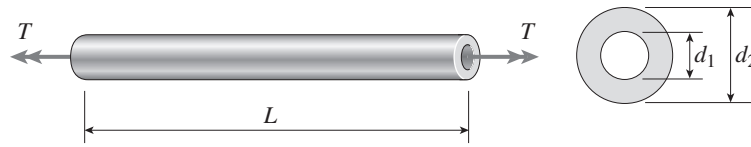
Solution 3.5-3 Tubular bar

$$d_2 = 4.0 \text{ in.} \quad T = 70.0 \text{ k-in.} = 70,000 \text{ lb-in.}$$

$$\sigma_{\max} = 6400 \text{ psi} \quad \tau_{\max} = \sigma_{\max} = 6400 \text{ psi}$$

(a) INSIDE DIAMETER d_1

$$\text{Torsion formula: } \tau_{\max} = \frac{Tr}{I_p} = \frac{Td_2}{2I_p}$$

$$I_p = \frac{Td_2}{2\tau_{\max}} = \frac{(70.0 \text{ k-in.})(4.0 \text{ in.})}{2(6400 \text{ psi})}$$

$$= 21.875 \text{ in.}^4$$

$$\text{Also, } I_p = \frac{\pi}{32}(d_2^4 - d_1^4) = \frac{\pi}{32}[(4.0 \text{ in.})^4 - d_1^4]$$

Equate formulas:

$$\frac{\pi}{32}[256 \text{ in.}^4 - d_1^4] = 21.875 \text{ in.}^4$$

$$\text{Solve for } d_1: \quad d_1 = 2.40 \text{ in.} \quad \leftarrow$$

(b) ANGLE OF TWIST ϕ

$$L = 48 \text{ in.} \quad G = 4.0 \times 10^6 \text{ psi}$$

$$\phi = \frac{TL}{GI_p}$$

$$\text{From torsion formula, } T = \frac{2I_p\tau_{\max}}{d_2}$$

$$\therefore \phi = \frac{2I_p\tau_{\max}}{d_2} \left(\frac{L}{GI_p} \right) = \frac{2L\tau_{\max}}{Gd_2}$$

$$= \frac{2(48 \text{ in.})(6400 \text{ psi})}{(4.0 \times 10^6 \text{ psi})(4.0 \text{ in.})} = 0.03840 \text{ rad}$$

$$\phi = 2.20^\circ \quad \leftarrow$$

(c) MAXIMUM SHEAR STRAIN

$$\gamma_{\max} = \frac{\tau_{\max}}{G} = \frac{6400 \text{ psi}}{4.0 \times 10^6 \text{ psi}}$$

$$= 1600 \times 10^{-6} \text{ rad} \quad \leftarrow$$

Problem 3.5-4 A solid circular bar of diameter $d = 50 \text{ mm}$ (see figure) is twisted in a testing machine until the applied torque reaches the value $T = 500 \text{ N} \cdot \text{m}$. At this value of torque, a strain gage oriented at 45° to the axis of the bar gives a reading $\epsilon = 339 \times 10^{-6}$.

What is the shear modulus G of the material?

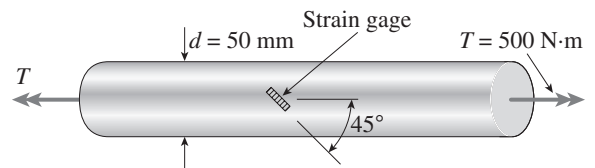
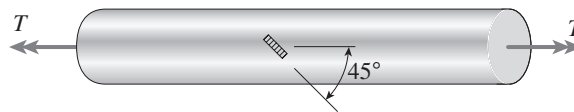
**Solution 3.5-4 Bar in a testing machine**Strain gage at 45° :

$$\epsilon_{\max} = 339 \times 10^{-6}$$

$$d = 50 \text{ mm}$$

$$T = 500 \text{ N} \cdot \text{m}$$

SHEAR STRAIN (FROM EQ. 3-33)

$$\gamma_{\max} = 2\epsilon_{\max} = 678 \times 10^{-6}$$

SHEAR STRESS (FROM EQ. 3-12)

$$\tau_{\max} = \frac{16T}{\pi d^3} = \frac{16(500 \text{ N} \cdot \text{m})}{\pi(0.050 \text{ m})^3} = 20.372 \text{ MPa}$$

SHEAR MODULUS

$$G = \frac{\tau_{\max}}{\gamma_{\max}} = \frac{20.372 \text{ MPa}}{678 \times 10^{-6}} = 30.0 \text{ GPa} \quad \leftarrow$$

Problem 3.5-5 A steel tube ($G = 11.5 \times 10^6$ psi) has an outer diameter $d_2 = 2.0$ in. and an inner diameter $d_1 = 1.5$ in. When twisted by a torque T , the tube develops a maximum normal strain of 170×10^{-6} .

What is the magnitude of the applied torque T ?

Solution 3.5-5 Steel tube

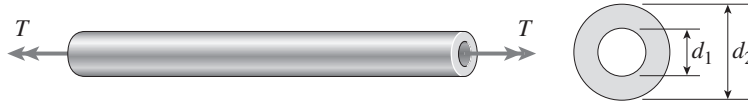

$$G = 11.5 \times 10^6 \text{ psi} \quad d_2 = 2.0 \text{ in.} \quad d_1 = 1.5 \text{ in.}$$

$$\varepsilon_{\max} = 170 \times 10^{-6}$$

$$I_P = \frac{\pi}{32} (d_2^4 - d_1^4) = \frac{\pi}{32} [(2.0 \text{ in.})^4 - (1.5 \text{ in.})^4]$$

$$= 1.07379 \text{ in.}^4$$

SHEAR STRAIN (FROM EQ. 3-33)

$$\gamma_{\max} = 2\varepsilon_{\max} = 340 \times 10^{-6}$$

SHEAR STRESS (FROM TORSION FORMULA)

$$\tau_{\max} = \frac{Tr}{I_P} = \frac{Td_2}{2I_P}$$

$$\text{Also, } \tau_{\max} = G\gamma_{\max}$$

Equate expressions:

$$\frac{Td_2}{2I_P} = G\gamma_{\max}$$

SOLVE FOR TORQUE

$$T = \frac{2GI_P\gamma_{\max}}{d_2}$$

$$= \frac{2(11.5 \times 10^6 \text{ psi})(1.07379 \text{ in.}^4)(340 \times 10^{-6})}{2.0 \text{ in.}}$$

$$= 4200 \text{ lb-in.} \quad \leftarrow$$

Problem 3.5-6 A solid circular bar of steel ($G = 78$ GPa) transmits a torque $T = 360$ N·m. The allowable stresses in tension, compression, and shear are 90 MPa, 70 MPa, and 40 MPa, respectively. Also, the allowable tensile strain is 220×10^{-6} .

Determine the minimum required diameter d of the bar.

Solution 3.5-6 Solid circular bar of steel

$$T = 360 \text{ N} \cdot \text{m} \quad G = 78 \text{ GPa}$$

ALLOWABLE STRESSES

Tension: 90 MPa Compression: 70 MPa

Shear: 40 MPa

$$\text{Allowable tensile strain: } \varepsilon_{\max} = 220 \times 10^{-6}$$

DIAMETER BASED UPON ALLOWABLE STRESS

The maximum tensile, compressive, and shear stresses in a bar in pure torsion are numerically equal. Therefore, the lowest allowable stress (shear stress) governs.

$$\tau_{\text{allow}} = 40 \text{ MPa}$$

$$\tau_{\max} = \frac{16T}{\pi d^3} \quad d^3 = \frac{16T}{\pi \tau_{\text{allow}}} = \frac{16(360 \text{ N} \cdot \text{m})}{\pi(40 \text{ MPa})}$$

$$d^3 = 45.837 \times 10^{-6} \text{ m}^3$$

$$d = 0.0358 \text{ m} = 35.8 \text{ mm}$$

DIAMETER BASED UPON ALLOWABLE TENSILE STRAIN

$$\gamma_{\max} = 2\varepsilon_{\max}; \quad \tau_{\max} = G\gamma_{\max} = 2G\varepsilon_{\max}$$

$$\tau_{\max} = \frac{16T}{\pi d^3} \quad d^3 = \frac{16T}{\pi \tau_{\max}} = \frac{16T}{2\pi G\varepsilon_{\max}}$$

$$d^3 = \frac{16(360 \text{ N} \cdot \text{m})}{2\pi(78 \text{ GPa})(220 \times 10^{-6})}$$

$$= 53.423 \times 10^{-6} \text{ m}^3$$

$$d = 0.0377 \text{ m} = 37.7 \text{ mm}$$

TENSILE STRAIN GOVERNS

$$d_{\min} = 37.7 \text{ mm} \quad \leftarrow$$

Problem 3.5-7 The normal strain in the 45° direction on the surface of a circular tube (see figure) is 880×10^{-6} when the torque $T = 750 \text{ lb-in.}$ The tube is made of copper alloy with $G = 6.2 \times 10^6 \text{ psi.}$

If the outside diameter d_2 of the tube is 0.8 in., what is the inside diameter d_1 ?

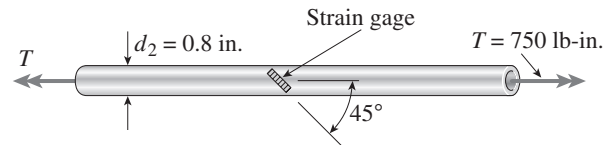
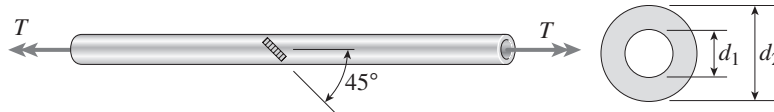
**Solution 3.5-7 Circular tube with strain gage**

$$d_2 = 0.80 \text{ in.} \quad T = 750 \text{ lb-in.} \quad G = 6.2 \times 10^6 \text{ psi}$$

$$\text{Strain gage at } 45^\circ: \varepsilon_{\max} = 880 \times 10^{-6}$$

MAXIMUM SHEAR STRAIN

$$\gamma_{\max} = 2\varepsilon_{\max}$$

MAXIMUM SHEAR STRESS

$$\tau_{\max} = G\gamma_{\max} = 2G\varepsilon_{\max}$$

$$\tau_{\max} = \frac{T(d_2/2)}{I_P} \quad I_P = \frac{Td_2}{2\tau_{\max}} = \frac{Td_2}{4G\varepsilon_{\max}}$$

$$I_P = \frac{\pi}{32}(d_2^4 - d_1^4) = \frac{Td_2}{4G\varepsilon_{\max}}$$

$$d_2^4 - d_1^4 = \frac{8Td_2}{\pi G\varepsilon_{\max}} \quad d_1^4 = d_2^4 - \frac{8Td_2}{\pi G\varepsilon_{\max}}$$

INSIDE DIAMETER

Substitute numerical values:

$$d_1^4 = (0.8 \text{ in.})^4 - \frac{8(750 \text{ lb-in.})(0.80 \text{ in.})}{\pi(6.2 \times 10^6 \text{ psi})(880 \times 10^{-6})}$$

$$= 0.4096 \text{ in.}^4 - 0.2800 \text{ in.}^4 = 0.12956 \text{ in.}^4$$

$$d_1 = 0.60 \text{ in.} \quad \leftarrow$$

Problem 3.5-8 An aluminum tube has inside diameter $d_1 = 50$ mm, shear modulus of elasticity $G = 27$ GPa, and torque $T = 4.0$ kN · m. The allowable shear stress in the aluminum is 50 MPa and the allowable normal strain is 900×10^{-6} .

Determine the required outside diameter d_2 .

Solution 3.5-8 Aluminum tube



$d_1 = 50$ mm $G = 27$ GPa
 $T = 4.0$ kN · m $\tau_{\text{allow}} = 50$ MPa $\epsilon_{\text{allow}} = 900 \times 10^{-6}$

NORMAL STRAIN GOVERNS

$\tau_{\text{allow}} = 48.60$ MPa

Determine the required diameter d_2 .

REQUIRED DIAMETER

ALLOWABLE SHEAR STRESS

$(\tau_{\text{allow}})_1 = 50$ MPa

$$\tau = \frac{Tr}{I_p} \quad 48.6 \text{ MPa} = \frac{(4000 \text{ N} \cdot \text{m})(d_2/2)}{\frac{\pi}{32}[d_2^4 - (0.050 \text{ m})^4]}$$

ALLOWABLE SHEAR STRESS BASED ON NORMAL STRAIN

$$\epsilon_{\text{max}} = \frac{\gamma}{2} = \frac{\tau}{2G} \quad \tau = 2G\epsilon_{\text{max}}$$

Rearrange and simplify:

$$d_2^4 - (419.174 \times 10^{-6})d_2 - 6.25 \times 10^{-6} = 0$$

$$\begin{aligned} (\tau_{\text{allow}})_2 &= 2G\epsilon_{\text{allow}} = 2(27 \text{ GPa})(900 \times 10^{-6}) \\ &= 48.6 \text{ MPa} \end{aligned}$$

Solve numerically:

$d_2 = 0.07927$ m

$d_2 = 79.3$ mm ←

Problem 3.5-9 A solid steel bar ($G = 11.8 \times 10^6$ psi) of diameter $d = 2.0$ in. is subjected to torques $T = 8.0$ k-in. acting in the directions shown in the figure.

- (a) Determine the maximum shear, tensile, and compressive stresses in the bar and show these stresses on sketches of properly oriented stress elements.
- (b) Determine the corresponding maximum strains (shear, tensile, and compressive) in the bar and show these strains on sketches of the deformed elements.

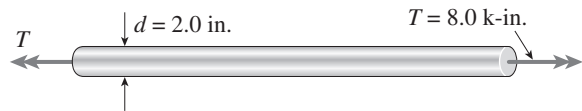

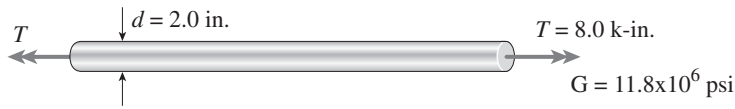
Solution 3.5-9 Solid steel bar

$$T = 8.0 \text{ k-in.}$$

$$G = 11.8 \times 10^6 \text{ psi}$$

(a) MAXIMUM STRESSES

$$\tau_{\max} = \frac{16T}{\pi d^3} = \frac{16(8000 \text{ lb-in.})}{\pi(2.0 \text{ in.})^3}$$

$$= 5093 \text{ psi} \quad \leftarrow$$

$$\sigma_t = 5090 \text{ psi} \quad \sigma_c = -5090 \text{ psi} \quad \leftarrow$$

(b) MAXIMUM STRAINS

$$\gamma_{\max} = \frac{\tau_{\max}}{G} = \frac{5093 \text{ psi}}{11.8 \times 10^6 \text{ psi}}$$

$$= 432 \times 10^{-6} \text{ rad} \quad \leftarrow$$

$$\epsilon_{\max} = \frac{\gamma_{\max}}{2} = 216 \times 10^{-6}$$

$$\epsilon_t = 216 \times 10^{-6} \quad \epsilon_c = -216 \times 10^{-6} \quad \leftarrow$$

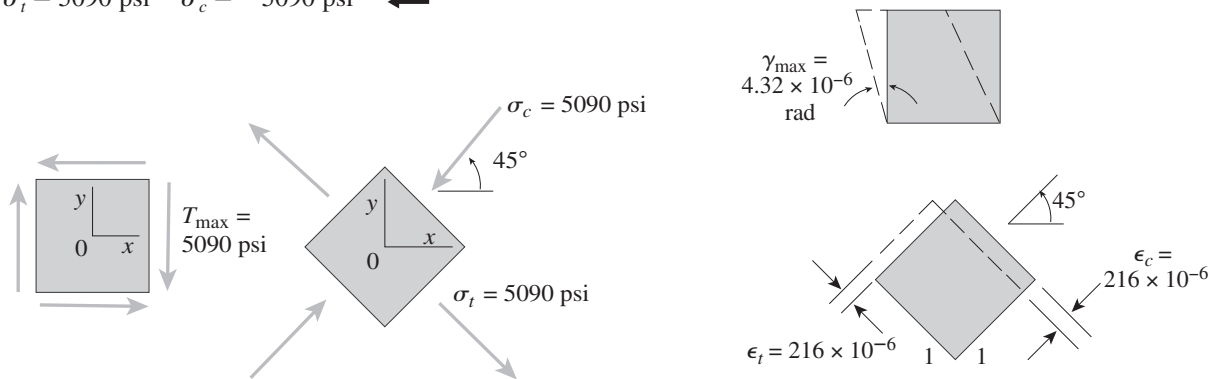

Problem 3.5-10 A solid aluminum bar ($G = 27 \text{ GPa}$) of diameter $d = 40 \text{ mm}$ is subjected to torques $T = 300 \text{ N} \cdot \text{m}$ acting in the directions shown in the figure.

- Determine the maximum shear, tensile, and compressive stresses in the bar and show these stresses on sketches of properly oriented stress elements.
- Determine the corresponding maximum strains (shear, tensile, and compressive) in the bar and show these strains on sketches of the deformed elements.

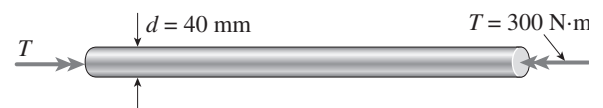

Solution 3.5-10 Solid aluminum bar



(a) MAXIMUM STRESSES

$$\tau_{\max} = \frac{16T}{\pi d^3} = \frac{16(300 \text{ N} \cdot \text{m})}{\pi(0.040 \text{ m})^3}$$

$$= 23.87 \text{ MPa} \quad \leftarrow$$

$$\sigma_t = 23.9 \text{ MPa} \quad \sigma_c = -23.9 \text{ MPa} \quad \leftarrow$$

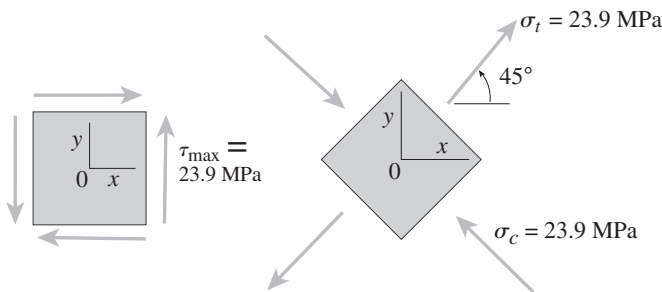

(b) MAXIMUM STRAINS

$$\gamma_{\max} = \frac{\tau_{\max}}{G} = \frac{23.87 \text{ MPa}}{27 \text{ GPa}}$$

$$= 884 \times 10^{-6} \text{ rad} \quad \leftarrow$$

$$\epsilon_{\max} = \frac{\gamma_{\max}}{2} = 442 \times 10^{-6}$$

$$\epsilon_t = 442 \times 10^{-6} \quad \epsilon_c = -442 \times 10^{-6} \quad \leftarrow$$

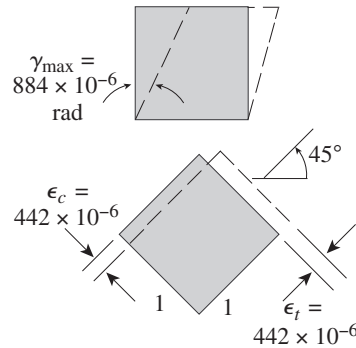

Transmission of Power

Problem 3.7-1 A generator shaft in a small hydroelectric plant turns at 120 rpm and delivers 50 hp (see figure).

- (a) If the diameter of the shaft is $d = 3.0$ in., what is the maximum shear stress τ_{\max} in the shaft?
- (b) If the shear stress is limited to 4000 psi, what is the minimum permissible diameter d_{\min} of the shaft?

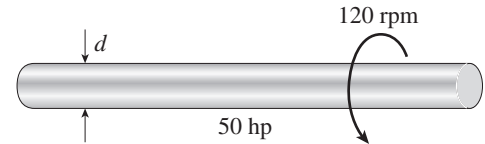

Solution 3.7-1 Generator shaft

$n = 120 \text{ rpm} \quad H = 50 \text{ hp} \quad d = \text{diameter}$

TORQUE

$$H = \frac{2\pi nT}{33,000} \quad H = \text{hp} \quad n = \text{rpm} \quad T = \text{lb-ft}$$

$$T = \frac{33,000 H}{2\pi n} = \frac{(33,000)(50 \text{ hp})}{2\pi(120 \text{ rpm})}$$

$$= 2188 \text{ lb-ft} = 26,260 \text{ lb-in.}$$

(a) MAXIMUM SHEAR STRESS τ_{\max}

$d = 3.0 \text{ in.}$

$$\tau_{\max} = \frac{16T}{\pi d^3} = \frac{16(26,260 \text{ lb-in.})}{\pi(3.0 \text{ in.})^3}$$

$\tau_{\max} = 4950 \text{ psi} \quad \leftarrow$

(b) MINIMUM DIAMETER d_{\min}

$\tau_{\text{allow}} = 4000 \text{ psi}$

$$d^3 = \frac{16T}{\pi \tau_{\text{allow}}} = \frac{16(26,260 \text{ lb-in.})}{\pi(4000 \text{ psi})} = 334.44 \text{ in.}^3$$

$d_{\min} = 3.22 \text{ in.} \quad \leftarrow$

Problem 3.7-2 A motor drives a shaft at 12 Hz and delivers 20 kW of power (see figure).

- (a) If the shaft has a diameter of 30 mm, what is the maximum shear stress τ_{\max} in the shaft?
- (b) If the maximum allowable shear stress is 40 MPa, what is the minimum permissible diameter d_{\min} of the shaft?

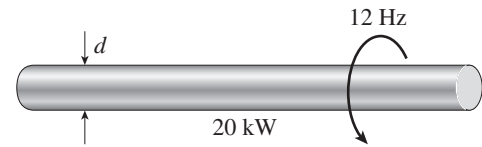

Solution 3.7-2 Motor-driven shaft

$$f = 12 \text{ Hz} \quad P = 20 \text{ kW} = 20,000 \text{ N} \cdot \text{m/s}$$

TORQUE

$$P = 2\pi f T \quad P = \text{watts} \quad f = \text{Hz} = \text{s}^{-1}$$

$T =$ Newton meters

$$T = \frac{P}{2\pi f} = \frac{20,000 \text{ W}}{2\pi(12 \text{ Hz})} = 265.3 \text{ N} \cdot \text{m}$$

(a) MAXIMUM SHEAR STRESS τ_{\max}

$$d = 30 \text{ mm}$$

$$\begin{aligned} \tau_{\max} &= \frac{16T}{\pi d^3} = \frac{16(265.3 \text{ N} \cdot \text{m})}{\pi(0.030 \text{ m})^3} \\ &= 50.0 \text{ MPa} \quad \leftarrow \end{aligned}$$

(b) MINIMUM DIAMETER d_{\min}

$$\tau_{\text{allow}} = 40 \text{ MPa}$$

$$\begin{aligned} d^3 &= \frac{16T}{\pi \tau_{\text{allow}}} = \frac{16(265.3 \text{ N} \cdot \text{m})}{\pi(40 \text{ MPa})} \\ &= 33.78 \times 10^{-6} \text{ m}^3 \end{aligned}$$

$$d_{\min} = 0.0323 \text{ m} = 32.3 \text{ mm} \quad \leftarrow$$

Problem 3.7-3 The propeller shaft of a large ship has outside diameter 18 in. and inside diameter 12 in., as shown in the figure. The shaft is rated for a maximum shear stress of 4500 psi.

- (a) If the shaft is turning at 100 rpm, what is the maximum horsepower that can be transmitted without exceeding the allowable stress?
- (b) If the rotational speed of the shaft is doubled but the power requirements remain unchanged, what happens to the shear stress in the shaft?

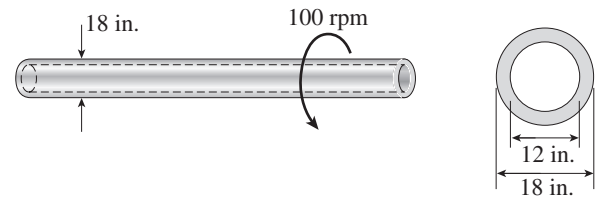

Solution 3.7-3 Hollow propeller shaft

$$d_2 = 18 \text{ in.} \quad d_1 = 12 \text{ in.} \quad \tau_{\text{allow}} = 4500 \text{ psi}$$

$$I_P = \frac{\pi}{32}(d_2^4 - d_1^4) = 8270.2 \text{ in.}^4$$

TORQUE

$$\tau_{\max} = \frac{T(d_2/2)}{I_P} \quad T = \frac{2\tau_{\text{allow}} I_P}{d_2}$$

$$\begin{aligned} T &= \frac{2(4500 \text{ psi})(8270.2 \text{ in.}^4)}{18 \text{ in.}} \\ &= 4.1351 \times 10^6 \text{ lb-in.} \\ &= 344,590 \text{ lb-ft.} \end{aligned}$$

(a) HORSEPOWER

$$n = 100 \text{ rpm} \quad H = \frac{2\pi n T}{33,000}$$

$$n = \text{rpm} \quad T = \text{lb-ft} \quad H = \text{hp}$$

$$\begin{aligned} H &= \frac{2\pi(100 \text{ rpm})(344,590 \text{ lb-ft})}{33,000} \\ &= 6560 \text{ hp} \quad \leftarrow \end{aligned}$$

(b) ROTATIONAL SPEED IS DOUBLED

$$H = \frac{2\pi n T}{33,000}$$

If n is doubled but H remains the same, then T is halved.

If T is halved, so is the maximum shear stress.

\therefore Shear stress is halved \leftarrow

Problem 3.7-4 The drive shaft for a truck (outer diameter 60 mm and inner diameter 40 mm) is running at 2500 rpm (see figure).

- (a) If the shaft transmits 150 kW, what is the maximum shear stress in the shaft?
- (b) If the allowable shear stress is 30 MPa, what is the maximum power that can be transmitted?

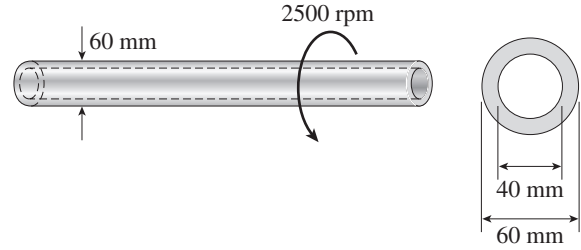

Solution 3.7-4 Drive shaft for a truck

$$d_2 = 60 \text{ mm} \quad d_1 = 40 \text{ mm} \quad n = 2500 \text{ rpm}$$

$$I_p = \frac{\pi}{32}(d_2^4 - d_1^4) = 1.0210 \times 10^{-6} \text{ m}^4$$

(a) MAXIMUM SHEAR STRESS τ_{\max}

$$P = \text{power (watts)} \quad P = 150 \text{ kW} = 150,000 \text{ W}$$

$$T = \text{torque (newton meters)} \quad n = \text{rpm}$$

$$P = \frac{2\pi n T}{60} \quad T = \frac{60P}{2\pi n}$$

$$T = \frac{60(150,000 \text{ W})}{2\pi(2500 \text{ rpm})} = 572.96 \text{ N} \cdot \text{m}$$

$$\tau_{\max} = \frac{Td_2}{2I_p} = \frac{(572.96 \text{ N} \cdot \text{m})(0.060 \text{ m})}{2(1.0210 \times 10^{-6} \text{ m}^4)}$$

$$= 16.835 \text{ MPa}$$

$$\tau_{\max} = 16.8 \text{ MPa} \quad \leftarrow$$

(b) MAXIMUM POWER P_{\max}

$$\tau_{\text{allow}} = 30 \text{ MPa}$$

$$P_{\max} = P \frac{\tau_{\text{allow}}}{\tau_{\max}} = (150 \text{ kW}) \left(\frac{30 \text{ MPa}}{16.835 \text{ MPa}} \right)$$

$$= 267 \text{ kW} \quad \leftarrow$$

Problem 3.7-5 A hollow circular shaft for use in a pumping station is being designed with an inside diameter equal to 0.75 times the outside diameter. The shaft must transmit 400 hp at 400 rpm without exceeding the allowable shear stress of 6000 psi.

Determine the minimum required outside diameter d .

Solution 3.7-5 Hollow shaft

d = outside diameter

d_0 = inside diameter

$$= 0.75 d$$

$$H = 400 \text{ hp} \quad n = 400 \text{ rpm}$$

$$\tau_{\text{allow}} = 6000 \text{ psi}$$

$$I_p = \frac{\pi}{32}[d^4 - (0.75 d)^4] = 0.067112 d^4$$

TORQUE

$$H = \frac{2\pi n T}{33,000}$$

$$H = \text{hp} \quad n = \text{rpm} \quad T = \text{lb-ft}$$

$$T = \frac{33,000 H}{2\pi n} = \frac{(33,000)(400 \text{ hp})}{2\pi(400 \text{ rpm})}$$

$$= 5252.1 \text{ lb-ft} = 63,025 \text{ lb-in.}$$

MINIMUM OUTSIDE DIAMETER

$$\tau_{\max} = \frac{Td}{2I_p} \quad I_p = \frac{Td}{2\tau_{\max}} = \frac{Td}{2\tau_{\text{allow}}}$$

$$0.067112 d^4 = \frac{(63,025 \text{ lb-in.})(d)}{2(6000 \text{ psi})}$$

$$d^3 = 78.259 \text{ in.}^3 \quad d_{\min} = 4.28 \text{ in.} \quad \leftarrow$$

Problem 3.7-6 A tubular shaft being designed for use on a construction site must transmit 120 kW at 1.75 Hz. The inside diameter of the shaft is to be one-half of the outside diameter.

If the allowable shear stress in the shaft is 45 MPa, what is the minimum required outside diameter d ?

Solution 3.7-6 Tubular shaft

d = outside diameter

d_0 = inside diameter
= $0.5 d$

$P = 120 \text{ kW} = 120,000 \text{ W}$ $f = 1.75 \text{ Hz}$

$\tau_{\text{allow}} = 45 \text{ MPa}$

$$I_p = \frac{\pi}{32} [d^4 - (0.5 d)^4] = 0.092039 d^4$$

TORQUE

$$P = 2\pi f T \quad P = \text{watts} \quad f = \text{Hz}$$

T = newton meters

$$T = \frac{P}{2\pi f} = \frac{120,000 \text{ W}}{2\pi(1.75 \text{ Hz})} = 10,913.5 \text{ N} \cdot \text{m}$$

MINIMUM OUTSIDE DIAMETER

$$\tau_{\text{max}} = \frac{Td}{2I_p} \quad I_p = \frac{Td}{2\tau_{\text{max}}} = \frac{Td}{2\tau_{\text{allow}}}$$

$$0.092039 d^4 = \frac{(10,913.5 \text{ N} \cdot \text{m})(d)}{2(45 \text{ MPa})}$$

$$d^3 = 0.0013175 \text{ m}^3 \quad d = 0.1096 \text{ m}$$

$$d_{\text{min}} = 110 \text{ mm} \quad \leftarrow$$

Problem 3.7-7 A propeller shaft of solid circular cross section and diameter d is spliced by a collar of the same material (see figure). The collar is securely bonded to both parts of the shaft.

What should be the minimum outer diameter d_1 of the collar in order that the splice can transmit the same power as the solid shaft?

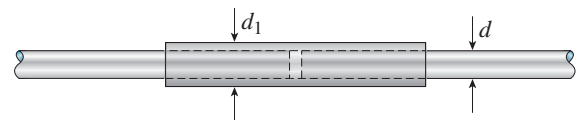

Solution 3.7-7 Splice in a propeller shaft

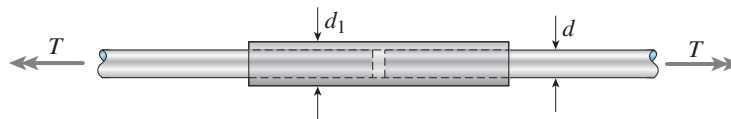

SOLID SHAFT

$$\tau_{\text{max}} = \frac{16T_1}{\pi d^3} \quad T_1 = \frac{\pi d^3 \tau_{\text{max}}}{16}$$

HOLLOW COLLAR

$$I_p = \frac{\pi}{32} (d_1^4 - d^4) \quad \tau_{\text{max}} = \frac{T_2 r}{I_p} = \frac{T_2 (d_1/2)}{I_p}$$

$$T_2 = \frac{2\tau_{\text{max}} I_p}{d_1} = \frac{2\tau_{\text{max}}}{d_1} \left(\frac{\pi}{32} (d_1^4 - d^4) \right)$$

$$= \frac{\pi \tau_{\text{max}}}{16 d_1} (d_1^4 - d^4)$$

EQUATE TORQUES

For the same power, the torques must be the same. For the same material, both parts can be stressed to the same maximum stress.

$$\therefore T_1 = T_2 \quad \frac{\pi d^3 \tau_{\text{max}}}{16} = \frac{\pi \tau_{\text{max}}}{16 d_1} (d_1^4 - d^4)$$

$$\text{or} \left(\frac{d_1}{d} \right)^4 - \frac{d_1}{d} - 1 = 0 \quad (\text{Eq. 1})$$

MINIMUM OUTER DIAMETER

Solve Eq. (1) numerically:

$$\text{Min. } d_1 = 1.221 d \quad \leftarrow$$

Problem 3.7-8 What is the maximum power that can be delivered by a hollow propeller shaft (outside diameter 50 mm, inside diameter 40 mm, and shear modulus of elasticity 80 GPa) turning at 600 rpm if the allowable shear stress is 100 MPa and the allowable rate of twist is $3.0^\circ/\text{m}$?

Solution 3.7-8 Hollow propeller shaft

$$d_2 = 50 \text{ mm} \quad d_1 = 40 \text{ mm}$$

$$G = 80 \text{ GPa} \quad n = 600 \text{ rpm}$$

$$\tau_{\text{allow}} = 100 \text{ MPa} \quad \theta_{\text{allow}} = 3.0^\circ/\text{m}$$

$$I_p = \frac{\pi}{32}(d_2^4 - d_1^4) = 362.3 \times 10^{-9} \text{ m}^4$$

BASED UPON ALLOWABLE SHEAR STRESS

$$\tau_{\text{max}} = \frac{T_1(d_2/2)}{I_p} \quad T_1 = \frac{2\tau_{\text{allow}}I_p}{d_2}$$

$$T_1 = \frac{2(100 \text{ MPa})(362.3 \times 10^{-9} \text{ m}^4)}{0.050 \text{ m}}$$

$$= 1449 \text{ N} \cdot \text{m}$$

BASED UPON ALLOWABLE RATE OF TWIST

$$\theta = \frac{T_2}{GI_p} \quad T_2 = GI_p\theta_{\text{allow}}$$

$$T_2 = (80 \text{ GPa})(362.3 \times 10^{-9} \text{ m}^4)(3.0^\circ/\text{m})$$

$$\times \left(\frac{\pi}{180} \text{ rad/degree} \right)$$

$$T_2 = 1517 \text{ N} \cdot \text{m}$$

SHEAR STRESS GOVERNS

$$T_{\text{allow}} = T_1 = 1449 \text{ N} \cdot \text{m}$$

MAXIMUM POWER

$$P = \frac{2\pi nT}{60} = \frac{2\pi(600 \text{ rpm})(1449 \text{ N} \cdot \text{m})}{60}$$

$$P = 91,047 \text{ W}$$

$$P_{\text{max}} = 91.0 \text{ kW} \quad \leftarrow$$

Problem 3.7-9 A motor delivers 275 hp at 1000 rpm to the end of a shaft (see figure). The gears at *B* and *C* take out 125 and 150 hp, respectively.

Determine the required diameter *d* of the shaft if the allowable shear stress is 7500 psi and the angle of twist between the motor and gear *C* is limited to 1.5° . (Assume $G = 11.5 \times 10^6$ psi, $L_1 = 6$ ft, and $L_2 = 4$ ft.)

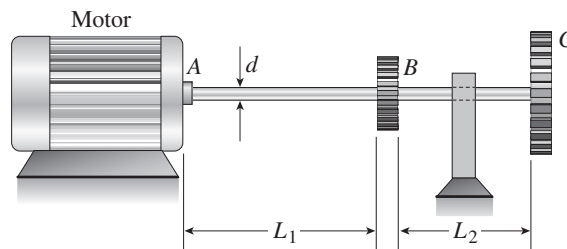

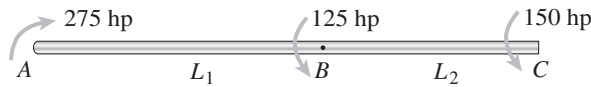
Solution 3.7-9 Motor-driven shaft

$$L_1 = 6 \text{ ft}$$

$$L_2 = 4 \text{ ft}$$

$$d = \text{diameter}$$

$$n = 1000 \text{ rpm}$$

$$\tau_{\text{allow}} = 7500 \text{ psi}$$

$$(\phi_{AC})_{\text{allow}} = 1.5^\circ = 0.02618 \text{ rad}$$

$$G = 11.5 \times 10^6 \text{ psi}$$

TORQUES ACTING ON THE SHAFT

$$H = \frac{2\pi n T}{33,000} \quad H = \text{hp} \quad n = \text{rpm} \quad T = \text{lb-ft}$$

$$T = \frac{33,000 H}{2\pi n}$$

$$\begin{aligned} \text{At point A: } T_A &= \frac{33,000(275 \text{ hp})}{2\pi(1000 \text{ rpm})} \\ &= 1444 \text{ lb-ft} \\ &= 17,332 \text{ lb-in.} \end{aligned}$$

$$\text{At point B: } T_B = \frac{125}{275} T_A = 7878 \text{ lb-in.}$$

$$\text{At point C: } T_C = \frac{150}{275} T_A = 9454 \text{ lb-in.}$$

FREE-BODY DIAGRAM

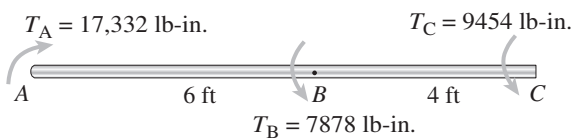

$$T_A = 17,332 \text{ lb-in.}$$

$$T_C = 9454 \text{ lb-in.}$$

$$d = \text{diameter}$$

$$T_B = 7878 \text{ lb-in.}$$

INTERNAL TORQUES

$$T_{AB} = 17,332 \text{ lb-in.}$$

$$T_{BC} = 9454 \text{ lb-in.}$$

DIAMETER BASED UPON ALLOWABLE SHEAR STRESS

The larger torque occurs in segment *AB*

$$\begin{aligned} \tau_{\text{max}} &= \frac{16T_{AB}}{\pi d^3} \quad d^3 = \frac{16T_{AB}}{\pi \tau_{\text{allow}}} \\ &= \frac{16(17,332 \text{ lb-in.})}{\pi(7500 \text{ psi})} = 11.77 \text{ in.}^3 \\ d &= 2.27 \text{ in.} \end{aligned}$$

DIAMETER BASED UPON ALLOWABLE ANGLE OF TWIST

$$I_P = \frac{\pi d^4}{32} \quad \phi = \frac{TL}{GI_P} = \frac{32TL}{\pi G d^4}$$

Segment *AB*:

$$\begin{aligned} \phi_{AB} &= \frac{32 T_{AB} L_{AB}}{\pi G d^4} \\ &= \frac{32(17,330 \text{ lb-in.})(6 \text{ ft})(12 \text{ in./ft})}{\pi(11.5 \times 10^6 \text{ psi})d^4} \end{aligned}$$

$$\phi_{AB} = \frac{1.1052}{d^4}$$

Segment *BC*:

$$\begin{aligned} \phi_{BC} &= \frac{32 T_{BC} L_{BC}}{\pi G d^4} \\ &= \frac{32(9450 \text{ lb-in.})(4 \text{ ft})(12 \text{ in./ft})}{\pi(11.5 \times 10^6 \text{ psi})d^4} \end{aligned}$$

$$\phi_{BC} = \frac{0.4018}{d^4}$$

$$\text{From A to C: } \phi_{AC} = \phi_{AB} + \phi_{BC} = \frac{1.5070}{d^4}$$

$$(\phi_{AC})_{\text{allow}} = 0.02618 \text{ rad}$$

$$\therefore 0.02618 = \frac{1.5070}{d^4} \quad \text{and} \quad d = 2.75 \text{ in.}$$

Angle of twist governs

$$d = 2.75 \text{ in.} \quad \leftarrow$$

Problem 3.7-10 The shaft ABC shown in the figure is driven by a motor that delivers 300 kW at a rotational speed of 32 Hz. The gears at B and C take out 120 and 180 kW, respectively. The lengths of the two parts of the shaft are $L_1 = 1.5$ m and $L_2 = 0.9$ m.

Determine the required diameter d of the shaft if the allowable shear stress is 50 MPa, the allowable angle of twist between points A and C is 4.0° , and $G = 75$ GPa.

Solution 3.7-10 Motor-driven shaft

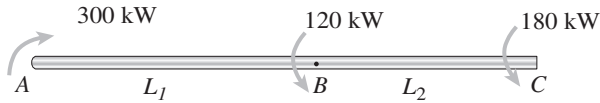

$$L_1 = 1.5 \text{ m}$$

$$L_2 = 0.9 \text{ m}$$

$$d = \text{diameter}$$

$$f = 32 \text{ Hz}$$

$$\tau_{\text{allow}} = 50 \text{ MPa}$$

$$G = 75 \text{ GPa}$$

$$(\phi_{AC})_{\text{allow}} = 4^\circ = 0.06981 \text{ rad}$$

TORQUES ACTING ON THE SHAFT

$$P = 2\pi f T \quad P = \text{watts} \quad f = \text{Hz}$$

$$T = \text{newton meters}$$

$$T = \frac{P}{2\pi f}$$

$$\text{At point A: } T_A = \frac{300,000 \text{ W}}{2\pi(32 \text{ Hz})} = 1492 \text{ N} \cdot \text{m}$$

$$\text{At point B: } T_B = \frac{120}{300} T_A = 596.8 \text{ N} \cdot \text{m}$$

$$\text{At point C: } T_C = \frac{180}{300} T_A = 895.3 \text{ N} \cdot \text{m}$$

FREE-BODY DIAGRAM

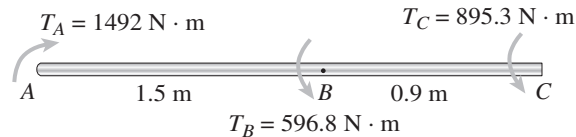

$$T_A = 1492 \text{ N} \cdot \text{m}$$

$$T_B = 596.8 \text{ N} \cdot \text{m}$$

$$T_C = 895.3 \text{ N} \cdot \text{m}$$

$$d = \text{diameter}$$

INTERNAL TORQUES

$$T_{AB} = 1492 \text{ N} \cdot \text{m}$$

$$T_{BC} = 895.3 \text{ N} \cdot \text{m}$$

DIAMETER BASED UPON ALLOWABLE SHEAR STRESS

The larger torque occurs in segment AB

$$\tau_{\text{max}} = \frac{16 T_{AB}}{\pi d^3} \quad d^3 = \frac{16 T_{AB}}{\pi \tau_{\text{allow}}} = \frac{16(1492 \text{ N} \cdot \text{m})}{\pi(50 \text{ MPa})}$$

$$d^3 = 0.0001520 \text{ m}^3 \quad d = 0.0534 \text{ m} = 53.4 \text{ mm}$$

DIAMETER BASED UPON ALLOWABLE ANGLE OF TWIST

$$I_P = \frac{\pi d^4}{32} \quad \phi = \frac{TL}{GI_P} = \frac{32TL}{\pi G d^4}$$

Segment AB :

$$\phi_{AB} = \frac{32 T_{AB} L_{AB}}{\pi G d^4} = \frac{32(1492 \text{ N} \cdot \text{m})(1.5 \text{ m})}{\pi(75 \text{ GPa})d^4}$$

$$\phi_{AB} = \frac{0.3039 \times 10^{-6}}{d^4}$$

Segment BC :

$$\phi_{BC} = \frac{32 T_{BC} L_{BC}}{\pi G d^4} = \frac{32(895.3 \text{ N} \cdot \text{m})(0.9 \text{ m})}{\pi(75 \text{ GPa})d^4}$$

$$\phi_{BC} = \frac{0.1094 \times 10^{-6}}{d^4}$$

$$\text{From A to C: } \phi_{AC} = \phi_{AB} + \phi_{BC} = \frac{0.4133 \times 10^{-6}}{d^4}$$

$$(\phi_{AC})_{\text{allow}} = 0.06981 \text{ rad}$$

$$\therefore 0.06981 = \frac{0.4133 \times 10^{-6}}{d^4}$$

$$\text{and } d = 0.04933 \text{ m} \\ = 49.3 \text{ mm}$$

SHEAR STRESS GOVERNS

$$d = 53.4 \text{ mm} \quad \leftarrow$$

Statically Indeterminate Torsional Members

Problem 3.8-1 A solid circular bar $ABCD$ with fixed supports is acted upon by torques T_0 and $2T_0$ at the locations shown in the figure.

Obtain a formula for the maximum angle of twist ϕ_{\max} of the bar. (Hint: Use Eqs. 3-46a and b of Example 3-9 to obtain the reactive torques.)

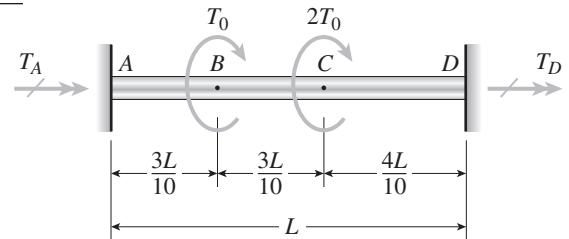
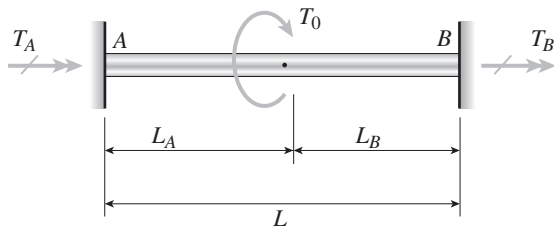
**Solution 3.8-1** Circular bar with fixed ends

From Eqs. (3-46a and b):

$$T_A = \frac{T_0 L_B}{L}$$

$$T_B = \frac{T_0 L_A}{L}$$

APPLY THE ABOVE FORMULAS TO THE GIVEN BAR:

$$T_A = T_0 \left(\frac{7}{10} \right) + 2T_0 \left(\frac{4}{10} \right) = \frac{15T_0}{10}$$

$$T_D = T_0 \left(\frac{3}{10} \right) + 2T_0 \left(\frac{6}{10} \right) = \frac{15T_0}{10}$$

ANGLE OF TWIST AT SECTION B

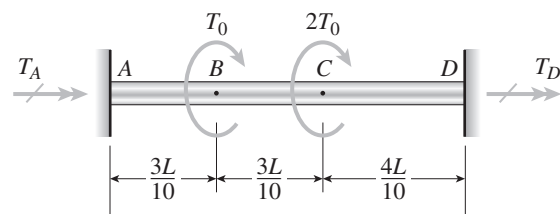

$$\phi_B = \phi_{AB} = \frac{T_A (3L/10)}{GI_P} = \frac{9T_0 L}{20GI_P}$$

ANGLE OF TWIST AT SECTION C

$$\phi_C = \phi_{CD} = \frac{T_D (4L/10)}{GI_P} = \frac{3T_0 L}{5GI_P}$$

MAXIMUM ANGLE OF TWIST

$$\phi_{\max} = \phi_C = \frac{3T_0 L}{5GI_P} \quad \leftarrow$$

Problem 3.8-2 A solid circular bar $ABCD$ with fixed supports at ends A and D is acted upon by two equal and oppositely directed torques T_0 , as shown in the figure. The torques are applied at points B and C , each of which is located at distance x from one end of the bar. (The distance x may vary from zero to $L/2$.)

- For what distance x will the angle of twist at points B and C be a maximum?
- What is the corresponding angle of twist ϕ_{\max} ? (Hint: Use Eqs. 3-46a and b of Example 3-9 to obtain the reactive torques.)

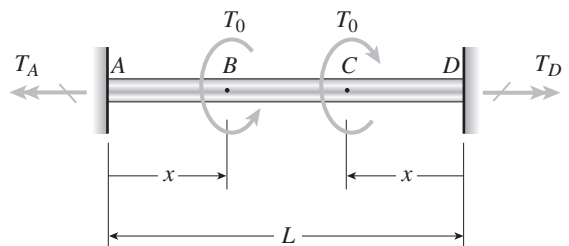

Solution 3.8-2 Circular bar with fixed ends

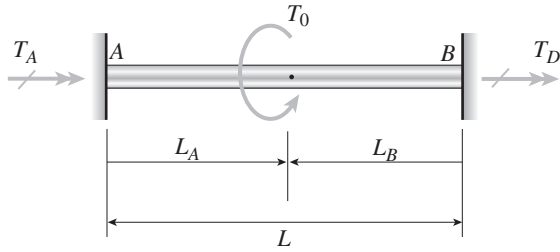

From Eqs. (3-46a and b):

$$T_A = \frac{T_0 L_B}{L}$$

$$T_B = \frac{T_0 L_A}{L}$$

APPLY THE ABOVE FORMULAS TO THE GIVEN BAR:

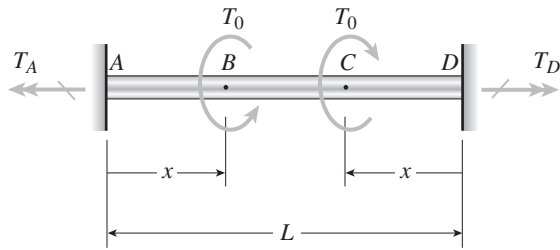

$$T_A = \frac{T_0(L-x)}{L} - \frac{T_0 x}{L} = \frac{T_0}{L}(L-2x) \quad T_D = T_A$$

(a) ANGLE OF TWIST AT SECTIONS B AND C

$$\phi_B = \phi_{AB} = \frac{T_A x}{GI_P} = \frac{T_0}{GI_P L} (L-2x)(x)$$

$$\frac{d\phi_B}{dx} = \frac{T_0}{GI_P L} (L-4x)$$

$$\frac{d\phi_B}{dx} = 0; \quad L-4x = 0$$

$$\text{or } x = \frac{L}{4} \quad \leftarrow$$

(b) MAXIMUM ANGLE OF TWIST

$$\phi_{\max} = (\phi_B)_{\max} = (\phi_B)_{x=L/4} = \frac{T_0 L}{8GI_P} \quad \leftarrow$$

Problem 3.8-3 A solid circular shaft AB of diameter d is fixed against rotation at both ends (see figure). A circular disk is attached to the shaft at the location shown.

What is the largest permissible angle of rotation ϕ_{\max} of the disk if the allowable shear stress in the shaft is τ_{allow} ? (Assume that $a > b$. Also, use Eqs. 3-46a and b of Example 3-9 to obtain the reactive torques.)

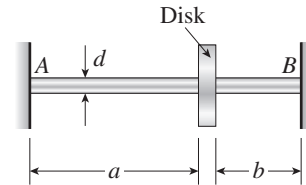

Solution 3.8-3 Shaft fixed at both ends

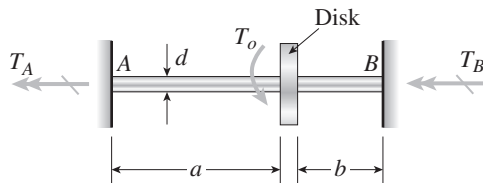

$$L = a + b$$

$$a > b$$

Assume that a torque T_0 acts at the disk.

The reactive torques can be obtained from Eqs. (3-46a and b):

$$T_A = \frac{T_0 b}{L} \quad T_B = \frac{T_0 a}{L}$$

Since $a > b$, the larger torque (and hence the larger stress) is in the right hand segment.

$$\tau_{\max} = \frac{T_B(d/2)}{I_P} = \frac{T_0 a d}{2LI_P}$$

$$T_0 = \frac{2LI_P \tau_{\max}}{ad} \quad (T_0)_{\max} = \frac{2LI_P \tau_{\text{allow}}}{ad}$$

ANGLE OF ROTATION OF THE DISK (FROM Eq. 3-49)

$$\phi = \frac{T_0 a b}{GLI_P}$$

$$\phi_{\max} = \frac{(T_0)_{\max} a b}{GLI_P} = \frac{2b \tau_{\text{allow}}}{Gd} \quad \leftarrow$$

Problem 3.8-4 A hollow steel shaft ACB of outside diameter 50 mm and inside diameter 40 mm is held against rotation at ends A and B (see figure). Horizontal forces P are applied at the ends of a vertical arm that is welded to the shaft at point C .

Determine the allowable value of the forces P if the maximum permissible shear stress in the shaft is 45 MPa. (Hint: Use Eqs. 3-46a and b of Example 3-9 to obtain the reactive torques.)

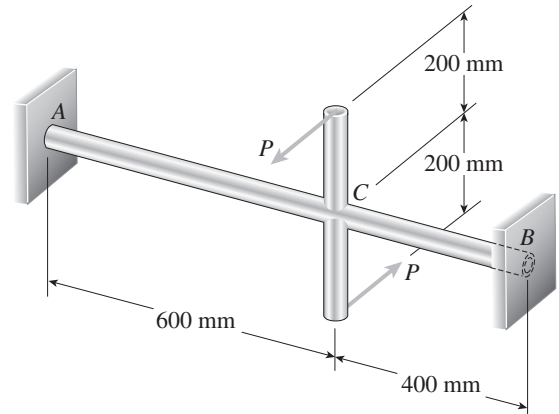

Solution 3.8-4 Hollow shaft with fixed ends

GENERAL FORMULAS:

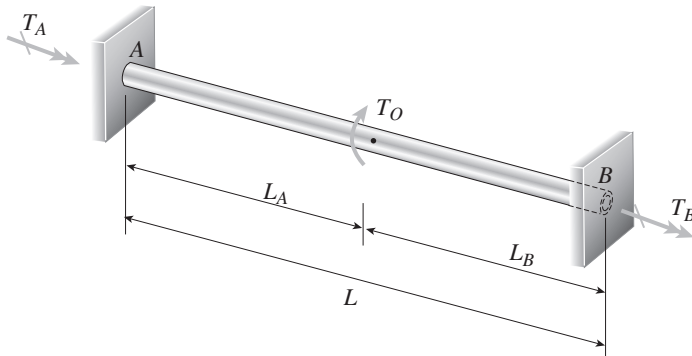

From Eqs. (3-46a and b):

$$T_A = \frac{T_0 L_B}{L}$$

$$T_B = \frac{T_0 L_A}{L}$$

APPLY THE ABOVE FORMULAS TO THE GIVEN SHAFT

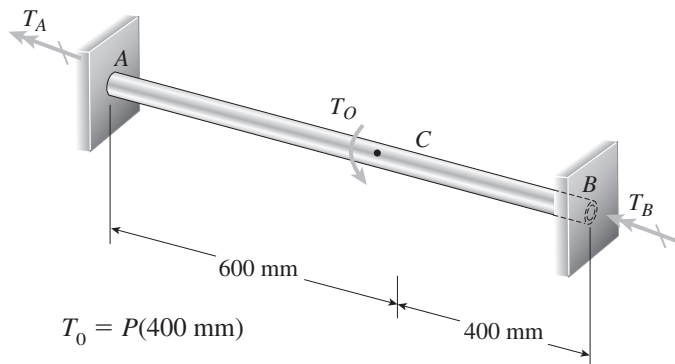

$$T_0 = P(400 \text{ mm})$$

$$L_B = 400 \text{ mm}$$

$$L_A = 600 \text{ mm}$$

$$L = L_A + L_B = 1000 \text{ mm}$$

$$d_2 = 50 \text{ mm} \quad d_1 = 40 \text{ mm}$$

$$\tau_{\text{allow}} = 45 \text{ MPa}$$

$$T_A = \frac{T_0 L_B}{L} = \frac{P(0.4 \text{ m})(400 \text{ mm})}{1000 \text{ mm}} = 0.16 P$$

$$T_B = \frac{T_0 L_A}{L} = \frac{P(0.4 \text{ m})(600 \text{ mm})}{1000 \text{ mm}} = 0.24 P$$

UNITS: P = Newtons T = Newton meters

The larger torque, and hence the larger shear stress, occurs in part CB of the shaft.

$$\therefore T_{\text{max}} = T_B = 0.24 P$$

SHEAR STRESS IN PART CB

$$\tau_{\text{max}} = \frac{T_{\text{max}}(d/2)}{I_P} \quad T_{\text{max}} = \frac{2\tau_{\text{max}} I_P}{d} \quad (\text{Eq. 1})$$

UNITS: Newtons and meters

$$\tau_{\text{max}} = 45 \times 10^6 \text{ N/m}^2$$

$$I_P = \frac{\pi}{32}(d_2^4 - d_1^4) = 362.26 \times 10^{-9} \text{ m}^4$$

$$d = d_2 = 0.05 \text{ m}$$

Substitute numerical values into (Eq. 1):

$$0.24P = \frac{2(45 \times 10^6 \text{ N/m}^2)(362.26 \times 10^{-9} \text{ m}^4)}{0.05 \text{ m}}$$

$$= 652.07 \text{ N} \cdot \text{m}$$

$$P = \frac{652.07 \text{ N} \cdot \text{m}}{0.24 \text{ m}} = 2717 \text{ N}$$

$$P_{\text{allow}} = 2710 \text{ N} \quad \leftarrow$$

Problem 3.8-5 A stepped shaft ACB having solid circular cross sections with two different diameters is held against rotation at the ends (see figure).

If the allowable shear stress in the shaft is 6000 psi, what is the maximum torque $(T_0)_{\max}$ that may be applied at section C ? (Hint: Use Eqs. 3-45a and b of Example 3-9 to obtain the reactive torques.)

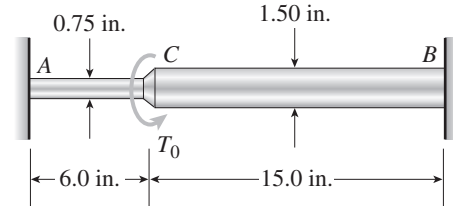

Solution 3.8-5 Stepped shaft ACB

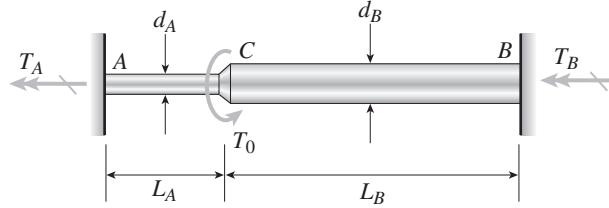

$$d_A = 0.75 \text{ in.}$$

$$d_B = 1.50 \text{ in.}$$

$$L_A = 6.0 \text{ in.}$$

$$L_B = 15.0 \text{ in.}$$

$$\tau_{\text{allow}} = 6000 \text{ psi}$$

Find $(T_0)_{\max}$

REACTIVE TORQUES (from Eqs. 3-45a and b)

$$T_A = T_0 \left(\frac{L_B I_{PB}}{L_B I_{PA} + L_A I_{PB}} \right) \quad (1)$$

$$T_B = T_0 \left(\frac{L_A I_{PB}}{L_B I_{PA} + L_A I_{PB}} \right) \quad (2)$$

ALLOWABLE TORQUE BASED UPON SHEAR STRESS
IN SEGMENT AC

$$\tau_{AC} = \frac{16T_A}{\pi d^3}$$

$$T_A = \frac{1}{16} \pi d_A^3 \tau_{AC} = \frac{1}{16} \pi d_A^3 \tau_{\text{allow}} \quad (3)$$

Combine Eqs. (1) and (3) and solve for T_0 :

$$\begin{aligned} (T_0)_{AC} &= \frac{1}{16} \pi d_A^3 \tau_{\text{allow}} \left(1 + \frac{L_A I_{PB}}{L_B I_{PA}} \right) \\ &= \frac{1}{16} \pi d_A^3 \tau_{\text{allow}} \left(1 + \frac{L_A d_B^4}{L_B d_A^4} \right) \end{aligned} \quad (4)$$

Substitute numerical values:

$$(T_0)_{AC} = 3678 \text{ lb-in.}$$

ALLOWABLE TORQUE BASED UPON SHEAR STRESS
IN SEGMENT CB

$$\tau_{CB} = \frac{16T_B}{\pi d_B^3}$$

$$T_B = \frac{1}{16} \pi d_B^3 \tau_{CB} = \frac{1}{16} \pi d_B^3 \tau_{\text{allow}} \quad (5)$$

Combine Eqs. (2) and (5) and solve for T_0 :

$$\begin{aligned} (T_0)_{CB} &= \frac{1}{16} \pi d_B^3 \tau_{\text{allow}} \left(1 + \frac{L_B I_{PA}}{L_A I_{PB}} \right) \\ &= \frac{1}{16} \pi d_B^3 \tau_{\text{allow}} \left(1 + \frac{L_B d_A^4}{L_A d_B^4} \right) \end{aligned} \quad (6)$$

Substitute numerical values:

$$(T_0)_{CB} = 4597 \text{ lb-in.}$$

SEGMENT AC GOVERNS

$$(T_0)_{\max} = 3680 \text{ lb-in.} \quad \leftarrow$$

NOTE: From Eqs. (4) and (6) we find that

$$\frac{(T_0)_{AC}}{(T_0)_{CB}} = \left(\frac{L_A}{L_B} \right) \left(\frac{d_B}{d_A} \right)$$

which can be used as a partial check on the results.

Problem 3.8-6 A stepped shaft ACB having solid circular cross sections with two different diameters is held against rotation at the ends (see figure).

If the allowable shear stress in the shaft is 43 MPa, what is the maximum torque $(T_0)_{\max}$ that may be applied at section C ? (Hint: Use Eqs. 3-45a and b of Example 3-9 to obtain the reactive torques.)

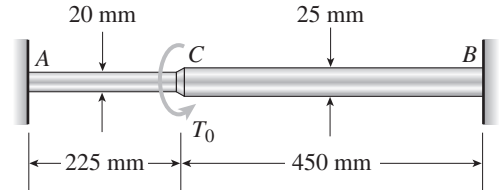

Solution 3.8-6 Stepped shaft ACB

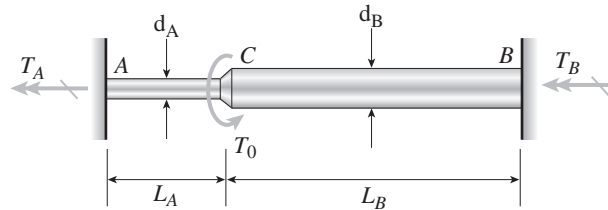

$$d_A = 20 \text{ mm}$$

$$d_B = 25 \text{ mm}$$

$$L_A = 225 \text{ mm}$$

$$L_B = 450 \text{ mm}$$

$$\tau_{\text{allow}} = 43 \text{ MPa}$$

Find $(T_0)_{\max}$

REACTIVE TORQUES (from Eqs. 3-45a and b)

$$T_A = T_0 \left(\frac{L_B I_{PA}}{L_B I_{PA} + L_A I_{PB}} \right) \quad (1)$$

$$T_B = T_0 \left(\frac{L_A I_{PB}}{L_B I_{PA} + L_A I_{PB}} \right) \quad (2)$$

ALLOWABLE TORQUE BASED UPON SHEAR STRESS IN SEGMENT AC

$$\tau_{AC} = \frac{16T_A}{\pi d_A^3}$$

$$T_A = \frac{1}{16} \pi d_A^3 \tau_{AC} = \frac{1}{16} \pi d_A^3 \tau_{\text{allow}} \quad (3)$$

Combine Eqs. (1) and (3) and solve for T_0 :

$$\begin{aligned} (T_0)_{AC} &= \frac{1}{16} \pi d_A^3 \tau_{\text{allow}} \left(1 + \frac{L_A I_{PB}}{L_B I_{PA}} \right) \\ &= \frac{1}{16} \pi d_A^3 \tau_{\text{allow}} \left(1 + \frac{L_A d_B^4}{L_B d_A^4} \right) \end{aligned} \quad (4)$$

Substitute numerical values:

$$(T_0)_{AC} = 150.0 \text{ N} \cdot \text{m}$$

ALLOWABLE TORQUE BASED UPON SHEAR STRESS IN SEGMENT CB

$$\tau_{CB} = \frac{16T_B}{\pi d_B^3}$$

$$T_B = \frac{1}{16} \pi d_B^3 \tau_{CB} = \frac{1}{16} \pi d_B^3 \tau_{\text{allow}} \quad (5)$$

Combine Eqs. (2) and (5) and solve for T_0 :

$$\begin{aligned} (T_0)_{CB} &= \frac{1}{16} \pi d_B^3 \tau_{\text{allow}} \left(1 + \frac{L_B I_{PA}}{L_A I_{PB}} \right) \\ &= \frac{1}{16} \pi d_B^3 \tau_{\text{allow}} \left(1 + \frac{L_B d_A^4}{L_A d_B^4} \right) \end{aligned} \quad (6)$$

Substitute numerical values:

$$(T_0)_{CB} = 240.0 \text{ N} \cdot \text{m}$$

SEGMENT AC GOVERNS

$$(T_0)_{\max} = 150 \text{ N} \cdot \text{m} \quad \leftarrow$$

NOTE: From Eqs. (4) and (6) we find that

$$\frac{(T_0)_{AC}}{(T_0)_{CB}} = \left(\frac{L_A}{L_B} \right) \left(\frac{d_B}{d_A} \right)$$

which can be used as a partial check on the results.

Problem 3.8-7 A stepped shaft ACB is held against rotation at ends A and B and subjected to a torque T_0 acting at section C (see figure). The two segments of the shaft (AC and CB) have diameters d_A and d_B , respectively, and polar moments of inertia I_{PA} and I_{PB} , respectively. The shaft has length L and segment AC has length a .

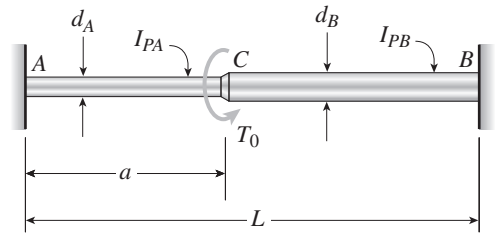

- (a) For what ratio a/L will the maximum shear stresses be the same in both segments of the shaft?
- (b) For what ratio a/L will the internal torques be the same in both segments of the shaft? (*Hint:* Use Eqs. 3-45a and b of Example 3-9 to obtain the reactive torques.)

Solution 3.8-7 Stepped shaft

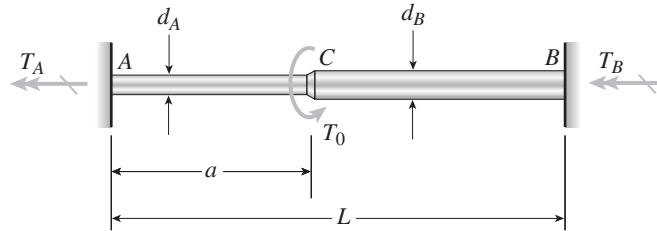

SEGMENT AC : $d_A, I_{PA} \quad L_A = a$

SEGMENT CB : $d_B, I_{PB} \quad L_B = L - a$

REACTIVE TORQUES (from Eqs. 3-45a and b)

$$T_A = T_0 \left(\frac{L_B I_{PA}}{L_B I_{PA} + L_A I_{PB}} \right); \quad T_B = T_0 \left(\frac{L_A I_{PB}}{L_B I_{PA} + L_A I_{PB}} \right)$$

(a) EQUAL SHEAR STRESSES

$$\tau_{AC} = \frac{T_A (d_A/2)}{I_{PA}} \quad \tau_{CB} = \frac{T_B (d_B/2)}{I_{PB}}$$

$$\tau_{AC} = \tau_{CB} \quad \text{or} \quad \frac{T_A d_A}{I_{PA}} = \frac{T_B d_B}{I_{PB}} \quad \text{(Eq. 1)}$$

Substitute T_A and T_B into Eq. (1):

$$\frac{L_B I_{PA} d_A}{I_{PA}} = \frac{L_A I_{PB} d_B}{I_{PB}} \quad \text{or} \quad L_B d_A = L_A d_B$$

$$\text{or} \quad (L-a)d_A = ad_B$$

$$\text{Solve for } a/L: \quad \frac{a}{L} = \frac{d_A}{d_A + d_B} \quad \leftarrow$$

(b) EQUAL TORQUES

$$T_A = T_B \quad \text{or} \quad L_B I_{PA} = L_A I_{PB}$$

$$\text{or} \quad (L-a) I_{PA} = a I_{PB}$$

$$\text{Solve for } a/L: \quad \frac{a}{L} = \frac{I_{PA}}{I_{PA} + I_{PB}}$$

$$\text{or} \quad \frac{a}{L} = \frac{d_A^4}{d_A^4 + d_B^4} \quad \leftarrow$$

Problem 3.8-8 A circular bar AB of length L is fixed against rotation at the ends and loaded by a distributed torque $t(x)$ that varies linearly in intensity from zero at end A to t_0 at end B (see figure).

Obtain formulas for the fixed-end torques T_A and T_B .

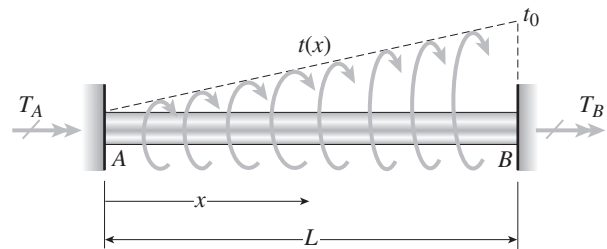

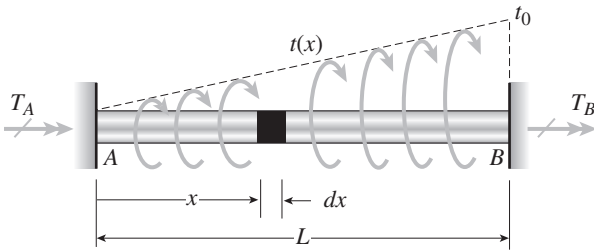
Solution 3.8-8 Fixed-end bar with triangular load

$$t(x) = \frac{t_0 x}{L}$$

T_0 = Resultant of distributed torque

$$T_0 = \int_0^L t(x) dx = \int_0^L \frac{t_0 x}{L} dx = \frac{t_0 L}{2}$$

EQUILIBRIUM

$$T_A + T_B = T_0 = \frac{t_0 L}{2}$$

ELEMENT OF DISTRIBUTED LOAD

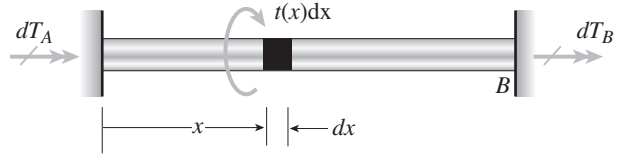

dT_A = Elemental reactive torque

dT_B = Elemental reactive torque

From Eqs. (3-46a and b):

$$dT_A = t(x) dx \left(\frac{L-x}{L} \right) \quad dT_B = t(x) dx \left(\frac{x}{L} \right)$$

REACTIVE TORQUES (FIXED-END TORQUES)

$$T_A = \int dT_A = \int_0^L \left(t_0 \frac{x}{L} \right) \left(\frac{L-x}{L} \right) dx = \frac{t_0 L}{6} \quad \leftarrow$$

$$T_B = \int dT_B = \int_0^L \left(t_0 \frac{x}{L} \right) \left(\frac{x}{L} \right) dx = \frac{t_0 L}{3} \quad \leftarrow$$

NOTE: $T_A + T_B = \frac{t_0 L}{2}$

Problem 3.8-9 A circular bar AB with ends fixed against rotation has a hole extending for half of its length (see figure). The outer diameter of the bar is $d_2 = 3.0$ in. and the diameter of the hole is $d_1 = 2.4$ in. The total length of the bar is $L = 50$ in.

At what distance x from the left-hand end of the bar should a torque T_0 be applied so that the reactive torques at the supports will be equal?

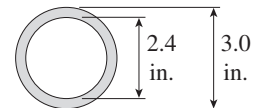
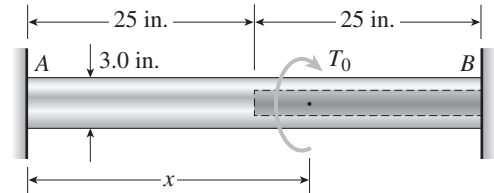

Solution 3.8-9 Bar with a hole

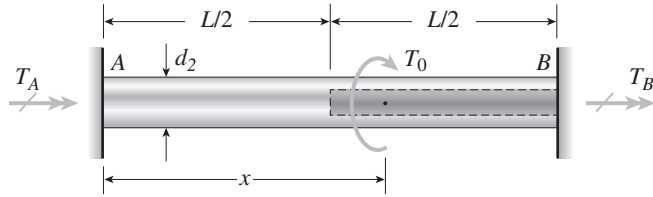

$L = 50 \text{ in.}$

$L/2 = 25 \text{ in.}$

$d_2 = \text{outer diameter}$

$= 3.0 \text{ in.}$

$d_1 = \text{diameter of hole}$

$= 2.4 \text{ in.}$

$T_0 = \text{Torque applied at distance } x$

Find x so that $T_A = T_B$

EQUILIBRIUM

$$T_A + T_B = T_0 \quad \therefore T_A = T_B = \frac{T_0}{2} \tag{1}$$

REMOVE THE SUPPORT AT END B

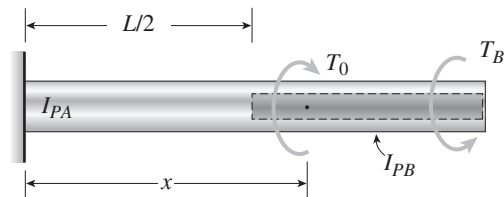

$\phi_B = \text{Angle of twist at } B$

$I_{PA} = \text{Polar moment of inertia at left-hand end}$

$I_{PB} = \text{Polar moment of inertia at right-hand end}$

$$\phi_B = \frac{T_B(L/2)}{GI_{PB}} + \frac{T_B(L/2)}{GI_{PA}} - \frac{T_0(x - L/2)}{GI_{PB}} - \frac{T_0(L/2)}{GI_{PA}} \tag{2}$$

Substitute Eq. (1) into Eq. (2) and simplify:

$$\phi_B = \frac{T_0}{G} \left[\frac{L}{4I_{PB}} + \frac{L}{4I_{PA}} - \frac{x}{I_{PB}} + \frac{L}{2I_{PB}} - \frac{L}{2I_{PA}} \right]$$

COMPATIBILITY $\phi_B = 0$

$$\therefore \frac{x}{I_{PB}} = \frac{3L}{4I_{PB}} - \frac{L}{4I_{PA}}$$

SOLVE FOR x :

$$x = \frac{L}{4} \left(3 - \frac{I_{PB}}{I_{PA}} \right)$$

$$\frac{I_{PB}}{I_{PA}} = \frac{d_2^4 - d_1^4}{d_2^4} = 1 - \left(\frac{d_1}{d_2} \right)^4$$

$$x = \frac{L}{4} \left[2 + \left(\frac{d_1}{d_2} \right)^4 \right] \quad \leftarrow$$

SUBSTITUTE NUMERICAL VALUES:

$$x = \frac{50 \text{ in.}}{4} \left[2 + \left(\frac{2.4 \text{ in.}}{3.0 \text{ in.}} \right)^4 \right] = 30.12 \text{ in.} \quad \leftarrow$$

Problem 3.8-10 A solid steel bar of diameter $d_1 = 25.0$ mm is enclosed by a steel tube of outer diameter $d_3 = 37.5$ mm and inner diameter $d_2 = 30.0$ mm (see figure). Both bar and tube are held rigidly by a support at end A and joined securely to a rigid plate at end B . The composite bar, which has a length $L = 550$ mm, is twisted by a torque $T = 400$ N · m acting on the end plate.

- Determine the maximum shear stresses τ_1 and τ_2 in the bar and tube, respectively.
- Determine the angle of rotation ϕ (in degrees) of the end plate, assuming that the shear modulus of the steel is $G = 80$ GPa.
- Determine the torsional stiffness k_T of the composite bar.
(Hint: Use Eqs. 3-44a and b to find the torques in the bar and tube.)

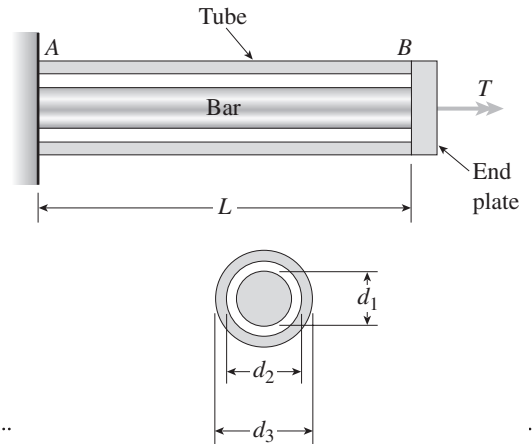

Solution 3.8-10 Bar enclosed in a tube

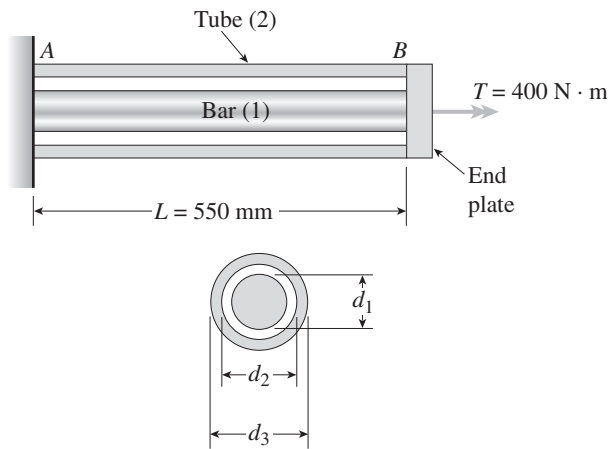

$$d_1 = 25.0 \text{ mm} \quad d_2 = 30.0 \text{ mm} \quad d_3 = 37.5 \text{ mm}$$

$$G = 80 \text{ GPa}$$

POLAR MOMENTS OF INERTIA

$$\text{Bar: } I_{P1} = \frac{\pi}{32} d_1^4 = 38.3495 \times 10^{-9} \text{ m}^4$$

$$\text{Tube: } I_{P2} = \frac{\pi}{32} (d_3^4 - d_2^4) = 114.6229 \times 10^{-9} \text{ m}^4$$

TORQUES IN THE BAR (1) AND TUBE (2)
FROM EQS. (3-44A AND B)

$$\text{Bar: } T_1 = T \left(\frac{I_{P1}}{I_{P1} + I_{P2}} \right) = 100.2783 \text{ N} \cdot \text{m}$$

$$\text{Tube: } T_2 = T \left(\frac{I_{P2}}{I_{P1} + I_{P2}} \right) = 299.7217 \text{ N} \cdot \text{m}$$

(a) MAXIMUM SHEAR STRESSES

$$\text{Bar: } \tau_1 = \frac{T_1 (d_1/2)}{I_{P1}} = 32.7 \text{ MPa} \quad \leftarrow$$

$$\text{Tube: } \tau_2 = \frac{T_2 (d_3/2)}{I_{P2}} = 49.0 \text{ MPa} \quad \leftarrow$$

(b) ANGLE OF ROTATION OF END PLATE

$$\phi = \frac{T_1 L}{G I_{P1}} = \frac{T_2 L}{G I_{P2}} = 0.017977 \text{ rad}$$

$$\phi = 1.03^\circ \quad \leftarrow$$

(c) TORSIONAL STIFFNESS

$$k_T = \frac{T}{\phi} = 22.3 \text{ kN} \cdot \text{m} \quad \leftarrow$$

Problem 3.8-11 A solid steel bar of diameter $d_1 = 1.50$ in. is enclosed by a steel tube of outer diameter $d_3 = 2.25$ in. and inner diameter $d_2 = 1.75$ in. (see figure). Both bar and tube are held rigidly by a support at end A and joined securely to a rigid plate at end B. The composite bar, which has length $L = 30.0$ in., is twisted by a torque $T = 5000$ lb-in. acting on the end plate.

- Determine the maximum shear stresses τ_1 and τ_2 in the bar and tube, respectively.
- Determine the angle of rotation ϕ (in degrees) of the end plate, assuming that the shear modulus of the steel is $G = 11.6 \times 10^6$ psi.
- Determine the torsional stiffness k_T of the composite bar. (*Hint:* Use Eqs. 3-44a and b to find the torques in the bar and tube.)

Solution 3.8-11 Bar enclosed in a tube

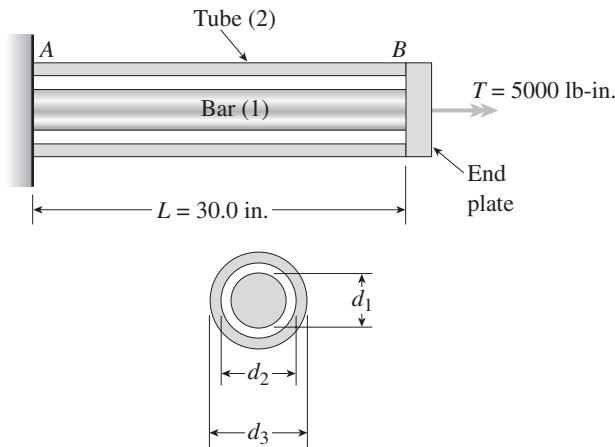

$$d_1 = 1.50 \text{ in.} \quad d_2 = 1.75 \text{ in.} \quad d_3 = 2.25 \text{ in.}$$

$$G = 11.6 \times 10^6 \text{ psi}$$

POLAR MOMENTS OF INERTIA

$$\text{Bar: } I_{p1} = \frac{\pi}{32} d_1^4 = 0.497010 \text{ in.}^4$$

$$\text{Tube: } I_{p2} = \frac{\pi}{32} (d_3^4 - d_2^4) = 1.595340 \text{ in.}^4$$

TORQUES IN THE BAR (1) AND TUBE (2)
FROM EQS. (3-44A AND B)

$$\text{Bar: } T_1 = T \left(\frac{I_{p1}}{I_{p1} + I_{p2}} \right) = 1187.68 \text{ lb-in.}$$

$$\text{Tube: } T_2 = T \left(\frac{I_{p2}}{I_{p1} + I_{p2}} \right) = 3812.32 \text{ lb-in.}$$

(a) MAXIMUM SHEAR STRESSES

$$\text{Bar: } \tau_1 = \frac{T_1(d_1/2)}{I_{p1}} = 1790 \text{ psi} \quad \leftarrow$$

$$\text{Tube: } \tau_2 = \frac{T_2(d_3/2)}{I_{p2}} = 2690 \text{ psi} \quad \leftarrow$$

(b) ANGLE OF ROTATION OF END PLATE

$$\phi = \frac{T_1 L}{G I_{p1}} = \frac{T_2 L}{G I_{p2}} = 0.00618015 \text{ rad}$$

$$\phi = 0.354^\circ \quad \leftarrow$$

(c) TORSIONAL STIFFNESS

$$k_T = \frac{T}{\phi} = 809 \text{ k-in.} \quad \leftarrow$$

Problem 3.8-12 The composite shaft shown in the figure is manufactured by shrink-fitting a steel sleeve over a brass core so that the two parts act as a single solid bar in torsion. The outer diameters of the two parts are $d_1 = 40$ mm for the brass core and $d_2 = 50$ mm for the steel sleeve. The shear moduli of elasticity are $G_b = 36$ GPa for the brass and $G_s = 80$ GPa for the steel.

Assuming that the allowable shear stresses in the brass and steel are $\tau_b = 48$ MPa and $\tau_s = 80$ MPa, respectively, determine the maximum permissible torque T_{\max} that may be applied to the shaft. (*Hint:* Use Eqs. 3-44a and b to find the torques.)

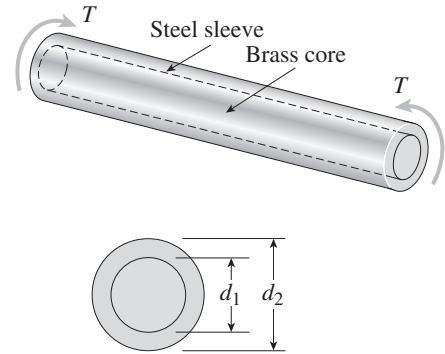

Solution 3.8-12 Composite shaft shrink fit

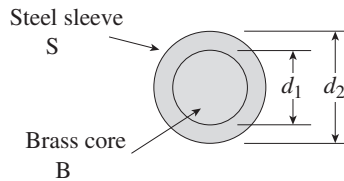

$$d_1 = 40 \text{ mm}$$

$$d_2 = 50 \text{ mm}$$

$$G_B = 36 \text{ GPa} \quad G_S = 80 \text{ GPa}$$

Allowable stresses:

$$\tau_B = 48 \text{ MPa} \quad \tau_S = 80 \text{ MPa}$$

BRASS CORE (ONLY)

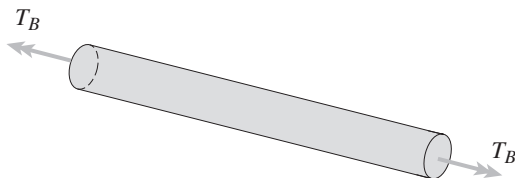

$$I_{PB} = \frac{\pi}{32} d_1^4 = 251.327 \times 10^{-9} \text{ m}^4$$

$$G_B I_{PB} = 9047.79 \text{ N} \cdot \text{m}^2$$

STEEL SLEEVE (ONLY)

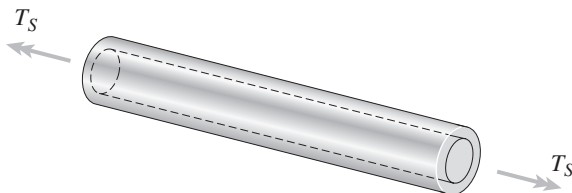

$$I_{PS} = \frac{\pi}{32} (d_2^4 - d_1^4) = 362.265 \times 10^{-9} \text{ m}^4$$

$$G_S I_{PS} = 28,981.2 \text{ N} \cdot \text{m}^2$$

TORQUES

$$\text{Total torque: } T = T_B + T_S$$

$$\text{Eq. (3-44a): } T_B = T \left(\frac{G_B I_{PB}}{G_B I_{PB} + G_S I_{PS}} \right) = 0.237918 T$$

$$\text{Eq. (3-44b): } T_S = T \left(\frac{G_S I_{PS}}{G_B I_{PB} + G_S I_{PS}} \right) = 0.762082 T$$

$$T = T_B + T_S \quad (\text{CHECK})$$

ALLOWABLE TORQUE T BASED UPON BRASS CORE

$$\tau_B = \frac{T_B (d_1/2)}{I_{PB}} \quad T_B = \frac{2\tau_B I_{PB}}{d_1}$$

Substitute numerical values:

$$T_B = 0.237918 T = \frac{2(48 \text{ MPa})(251.327 \times 10^{-9} \text{ m}^4)}{40 \text{ mm}}$$

$$T = 2535 \text{ N} \cdot \text{m}$$

ALLOWABLE TORQUE T BASED UPON STEEL SLEEVE

$$\tau_S = \frac{T_S (d_2/2)}{I_{PS}} \quad T_S = \frac{2\tau_S I_{PS}}{d_2}$$

SUBSTITUTE NUMERICAL VALUES:

$$T_S = 0.762082 T = \frac{2(80 \text{ MPa})(362.265 \times 10^{-9} \text{ m}^4)}{50 \text{ mm}}$$

$$T = 1521 \text{ N} \cdot \text{m}$$

STEEL SLEEVE GOVERNS $T_{\max} = 1520 \text{ N} \cdot \text{m}$ ←

Problem 3.8-13 The composite shaft shown in the figure is manufactured by shrink-fitting a steel sleeve over a brass core so that the two parts act as a single solid bar in torsion. The outer diameters of the two parts are $d_1 = 1.6$ in. for the brass core and $d_2 = 2.0$ in. for the steel sleeve. The shear moduli of elasticity are $G_b = 5400$ ksi for the brass and $G_s = 12,000$ ksi for the steel.

Assuming that the allowable shear stresses in the brass and steel are $\tau_b = 4500$ psi and $\tau_s = 7500$ psi, respectively, determine the maximum permissible torque T_{max} that may be applied to the shaft. (*Hint:* Use Eqs. 3-44a and b to find the torques.)

Solution 3.8-13 Composite shaft shrink fit

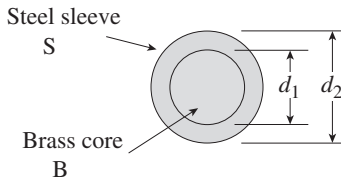

$d_1 = 1.6$ in.

$d_2 = 2.0$ in.

$G_B = 5,400$ psi $G_S = 12,000$ psi

Allowable stresses:

$\tau_B = 4500$ psi $\tau_S = 7500$ psi

BRASS CORE (ONLY)

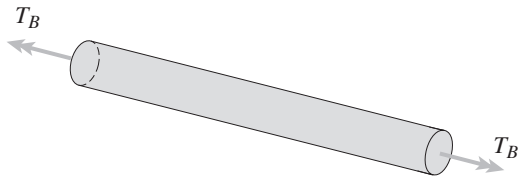

$I_{PB} = \frac{\pi}{32} d_1^4 = 0.643398 \text{ in.}^4$

$G_B I_{PB} = 3.47435 \times 10^6 \text{ lb-in.}^2$

STEEL SLEEVE (ONLY)

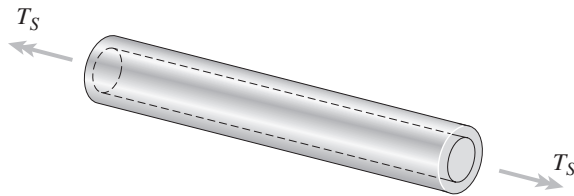

$I_{PS} = \frac{\pi}{32} (d_2^4 - d_1^4) = 0.927398 \text{ in.}^4$

$G_S I_{PS} = 11.1288 \times 10^6 \text{ lb-in.}^2$

TORQUES

Total torque: $T = T_B + T_S$

Eq. (3-44a): $T_B = T \left(\frac{G_B I_{PB}}{G_B I_{PB} + G_S I_{PS}} \right)$
 $= 0.237918 T$

Eq. (3-44b): $T_S = T \left(\frac{G_S I_{PS}}{G_B I_{PB} + G_S I_{PS}} \right)$
 $= 0.762082 T$

$T = T_B + T_S$ (CHECK)

ALLOWABLE TORQUE T BASED UPON BRASS CORE

$\tau_B = \frac{T_B (d_1/2)}{I_{PB}} \quad T_B = \frac{2\tau_B I_{PB}}{d_1}$

Substitute numerical values:

$T_B = 0.237918 T$
 $= \frac{2(4500 \text{ psi})(0.643398 \text{ in.}^4)}{1.6 \text{ in.}}$

$T = 15.21 \text{ k-in.}$

ALLOWABLE TORQUE T BASED UPON STEEL SLEEVE

$\tau_S = \frac{T_S (d_2/2)}{I_{PS}} \quad T_S = \frac{2\tau_S I_{PS}}{d_2}$

Substitute numerical values:

$T_S = 0.762082 T = \frac{2(7500 \text{ psi})(0.927398 \text{ in.}^4)}{2.0 \text{ in.}}$

$T = 9.13 \text{ k-in.}$

STEEL SLEEVE GOVERNS $T_{max} = 9.13 \text{ k-in.}$ ←

Problem 3.8-14 A steel shaft ($G_s = 80$ GPa) of total length $L = 4.0$ m is encased for one-half of its length by a brass sleeve ($G_b = 40$ GPa) that is securely bonded to the steel (see figure). The outer diameters of the shaft and sleeve are $d_1 = 70$ mm and $d_2 = 90$ mm, respectively.

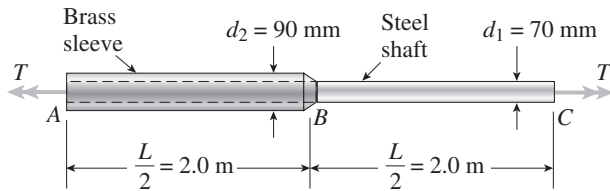

Solution 3.8-14 Composite shaft

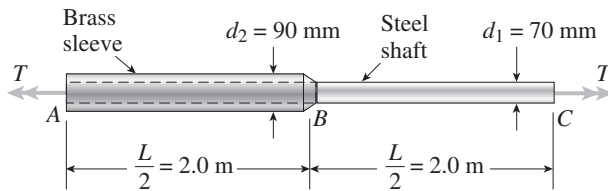

PROPERTIES OF THE STEEL SHAFT (s)

$$G_s = 80 \text{ GPa} \quad d_1 = 70 \text{ mm}$$

$$\text{Allowable shear stress: } \tau_s = 110 \text{ MPa}$$

$$I_{PS} = \frac{\pi}{32} d_1^4 = 2.3572 \times 10^{-6} \text{ m}^4$$

$$G_s I_{PS} = 188.574 \times 10^3 \text{ N} \cdot \text{m}^2$$

PROPERTIES OF THE BRASS SLEEVE (b)

$$G_b = 40 \text{ GPa} \quad d_2 = 90 \text{ mm} \quad d_1 = 70 \text{ mm}$$

$$\text{Allowable shear stress: } \tau_b = 70 \text{ MPa}$$

$$I_{PB} = \frac{\pi}{32} (d_2^4 - d_1^4) = 4.0841 \times 10^{-6} \text{ m}^4$$

$$G_b I_{PB} = 163.363 \times 10^3 \text{ N} \cdot \text{m}^2$$

TORQUES IN THE COMPOSITE BAR AB

$$T_s = \text{Torque in the steel shaft AB}$$

$$T_b = \text{Torque in the brass sleeve AB}$$

$$\text{From Eq. (3-44a): } T_s = T \left(\frac{G_s I_{PS}}{G_s I_{PS} + G_b I_{PB}} \right)$$

$$T_s = T(0.53582) \quad (\text{Eq. 1})$$

$$T_b = T - T_s = T(0.46418) \quad (\text{Eq. 2})$$

ANGLE OF TWIST OF THE COMPOSITE BAR AB

$$\phi_{AB} = \frac{T_s(L/2)}{G_s I_{PS}} = \frac{T_b(L/2)}{G_b I_{PB}}$$

$$= (5.6828 \times 10^{-6}) T \quad (\text{Eq. 3})$$

$$\text{UNITS: } T = \text{N} \cdot \text{m} \quad \phi = \text{rad}$$

- Determine the allowable torque T_1 that may be applied to the ends of the shaft if the angle of twist ϕ between the ends is limited to 8.0° .
- Determine the allowable torque T_2 if the shear stress in the brass is limited to $\tau_b = 70$ MPa.
- Determine the allowable torque T_3 if the shear stress in the steel is limited to $\tau_s = 110$ MPa.
- What is the maximum allowable torque T_{\max} if all three of the preceding conditions must be satisfied?

ANGLE OF TWIST OF PART BC OF THE STEEL SHAFT

$$\phi_{BC} = \frac{T(L/2)}{G_s I_{PS}} = (10.6059 \times 10^{-6}) T \quad (\text{Eq. 4})$$

ANGLE OF TWIST OF THE ENTIRE SHAFT ABC

$$\phi = \phi_{AB} + \phi_{BC} \quad (\text{Eqs. 3 and 4})$$

$$\phi = (16.2887 \times 10^{-6}) T$$

$$\text{UNITS: } \phi = \text{rad}$$

$$T = \text{N} \cdot \text{m}$$

- ALLOWABLE TORQUE T_1 BASED UPON ANGLE OF TWIST

$$\phi_{\text{allow}} = 8.0^\circ = 0.13963 \text{ rad}$$

$$\phi = (16.2887 \times 10^{-6}) T = 0.13963 \text{ rad}$$

$$T_1 = 8.57 \text{ kN} \cdot \text{m} \quad \leftarrow$$

- ALLOWABLE TORQUE T_2 BASED UPON SHEAR STRESS IN THE BRASS SLEEVE

$$\tau_b = \frac{T(d_2/2)}{I_{pb}} \quad \tau_b = 70 \text{ MPa}$$

$$T_b = 0.46418 T \quad (\text{From Eq. 2})$$

$$70 \text{ MPa} = \frac{(0.46418T)(0.045 \text{ m})}{4.0841 \times 10^{-6} \text{ m}^4}$$

$$\text{Solve for } T \text{ (Equal to } T_2\text{): } T_2 = 13.69 \text{ kN} \cdot \text{m} \quad \leftarrow$$

- ALLOWABLE TORQUE T_3 BASED UPON SHEAR STRESS IN THE STEEL SHAFT BC

$$\tau_s = \frac{T(d_2/2)}{I_{PS}} \quad \tau_s = 110 \text{ MPa}$$

$$110 \text{ MPa} = \frac{T(0.035 \text{ m})}{2.3572 \times 10^{-6} \text{ m}^4}$$

$$\text{Solve for } T \text{ (Equal to } T_3\text{):}$$

$$T_3 = 7.41 \text{ kN} \cdot \text{m} \quad \leftarrow$$

- MAXIMUM ALLOWABLE TORQUE

Shear stress in steel governs

$$T_{\max} = 7.41 \text{ kN} \cdot \text{m} \quad \leftarrow$$